

Saw Man-X

Inserto: Ampia gamma di Rompitruccioli disponibile

Portainseri: Lama (Base/con Refrigerante ad alta pressione), Portainsero (Autoserrante/Serraggio a vite)

Una soluzione per Scanalature Profonde e Troncatura

- Lavorazione stabile in scanalatura profonda grazie al sistema di serraggio con guida a V
- Precisione aumentata e sostituzione inserto ottimizzata grazie all'esclusiva chiave di serraggio

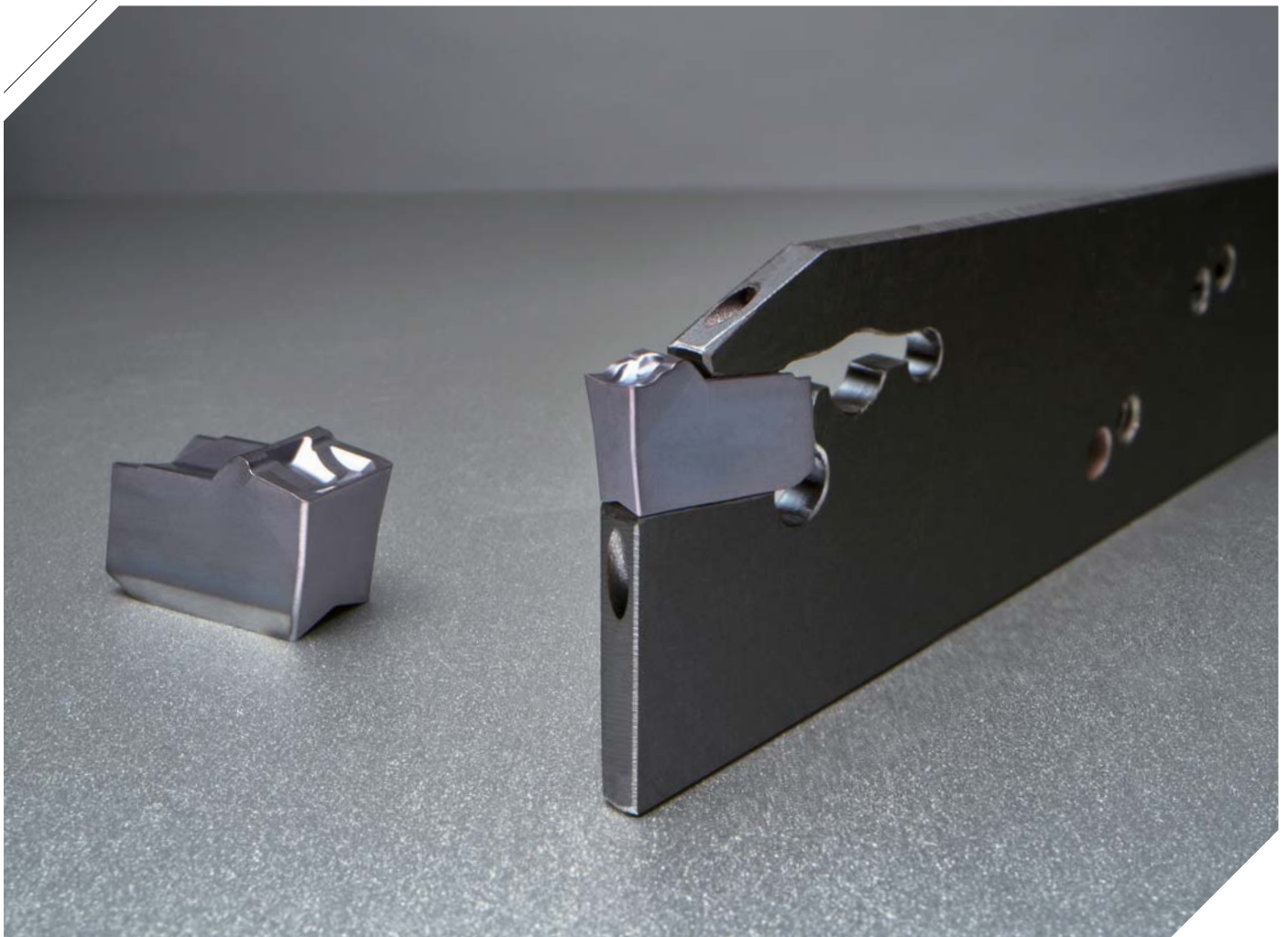

Una soluzione per Scanalature Profonde e Troncatura

Saw Man-X

La stabilità del sistema di serraggio, sia dell'inserto che del portainsero, è un fattore fondamentale nelle lavorazioni di troncatura e scanalatura profonda, in quanto le vibrazioni dovute alla lunga sporgenza e al ridotto spessore di lavorazione potrebbero portare alla rottura dell'inserto o del portainsero.

L'inserto Saw Man-X grazie a una guida a V concava (superiore, inferiore e posteriore) è stato appositamente progettato per aumentare la forza di serraggio. Il rompitruciolo, grazie alla speciale struttura dell'inserto, riduce efficacemente lo spessore del truciolo e minimizza le graffiature dovute all'impatto dei trucioli sulla superficie.

Il portainsero Saw Man-X ha una forte struttura di serraggio grazie alla guida a V convessa che assicura un alloggiamento dell'inserto stabile, ideale nelle lavorazioni ad alta velocità e ad alto avanzamento. In particolare, la lama e il blocco con getto interno del refrigerante ad alta pressione sfruttano al meglio il passaggio del refrigerante durante la lavorazione di materiali HRSA. L'esclusiva struttura autoserrante assicura un serraggio stabile e una lunga durata del utensile nelle lavorazioni con lunghe sporgenze. Il design innovativo dell'inserto e la chiave personalizzata contribuiscono ad aumentare la precisione del serraggio e facilitano la sostituzione dell'inserto.

La linea Saw Man-X assicura una lavorazione stabile, una lunga durata del portainsero e un sistema di serraggio preciso nelle lavorazioni ad alta velocità e ad alto avanzamento. Grazie a questi vantaggi, Saw Man-X è la soluzione efficace ed economica per la troncatura e la scanalatura profonda.

» **Serraggio stabile nelle lavorazioni ad alta velocità e avanzamento**

- Speciale Guida a V

» **Sostituzione dell'inserto ottimizzata**

- Chiave personalizzata

» **Varia gamma di rompitrucioli**

- N: Acciaio, Ghisa
- S: Inox, HRSA

» **Refrigerante interno ad alta pressione**

- Doppio getto diretto sul tagliente
- Durata aumentata nelle lavorazioni di materiali HRSA

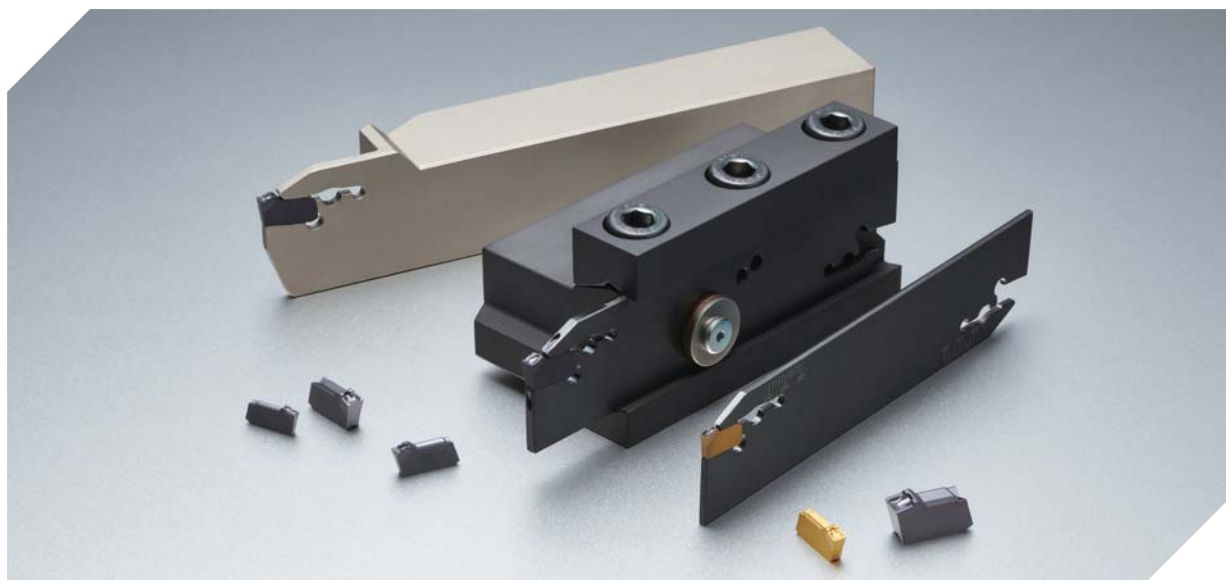

Codifica

Inserto (Base)

KSP	300	-	020	-	N
KORLOY Saw Man-X	Larghezza 200: 2 mm 300: 3 mm 400: 4 mm		Raggio di punta 020: 0.2 mm 030: 0.3 mm		Rompitruciolo N : Per P, K S : Per M, S

Inserto (Inclinato)

KSP	300	R	-	6D	-	N
KORLOY Saw Man-X	Larghezza 200: 2 mm 300: 3 mm 400: 4 mm	Direzione R: Destra L: Sinistra		Angolo 4D: 4° 6D: 6°		Rompitruciolo N : Per P, K S : Per M, S

Lama

KSPB	30	32	-	(KHP)
KORLOY Saw Man-X	Larghezza 20: 2 mm 30: 3 mm 40: 4 mm	Altezza Lama 26: 26 mm 32: 32 mm		Refrigerante Standard: Senza fori KHP: Sistema ad alta pressione

Autocentrante

KSPH	3	-	25	R
KORLOY Saw Man-X	Larghezza 2: 2 mm 3: 3 mm 4: 4 mm		Gambo 16: 1616 20: 2020 25: 2525	Direzione R: Destra L: Sinistra

Serraggio a vite

KS	E	H	R	25	25	-	2	-	T13
Korloy Saw Man-X	Utilizzo E: Esterno F: Frontale	Tipologia H: Orizzontale V: Verticale	Direzione R: Destra L: Sinistra	Altezza Portainsero 20: 20 mm 25: 25 mm	Larghezza Portainsero 20: 20 mm 25: 25 mm		Larghezza 2: 2 mm 3: 3 mm 4: 4 mm		T MAX T13: 13 mm

Caratteristiche

- Guida a V: serraggio stabile
- Rompitruciolo ottimizzato: migliore evacuazione
- Chiave personalizzata: serraggio preciso
- Possibilità di utilizzo del refrigerante ad alta pressione

Guida a V

- Serraggio robusto
- Vibrazioni minimizzate
- Indicato per lavorazioni ad alta velocità e scanalature profonde

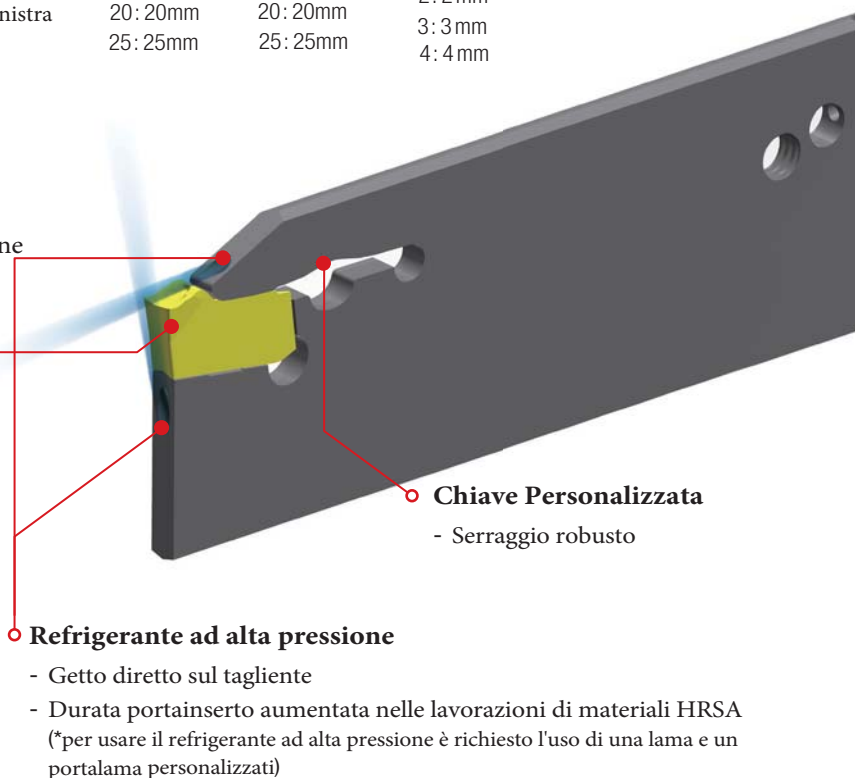
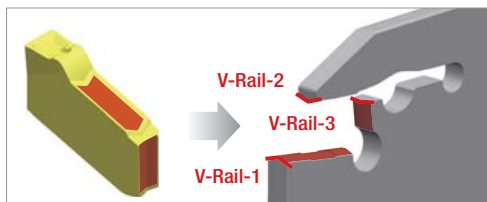

Chiave Personalizzata
- Serraggio robusto



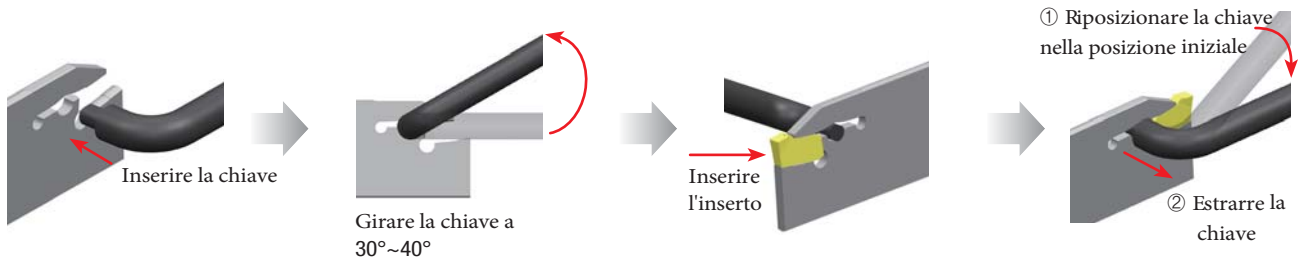

Refrigerante ad alta pressione

- Getto diretto sul tagliente
- Durata portainsero aumentata nelle lavorazioni di materiali HRSA (*per usare il refrigerante ad alta pressione è richiesto l'uso di una lama e un portalama personalizzati)

☑ Serraggio dell'Inserto

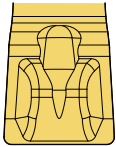
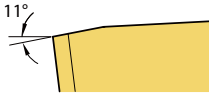

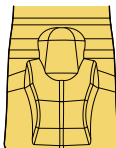
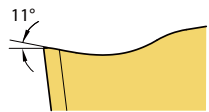
☑ Gamma dei Rompitruccioli

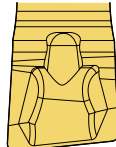
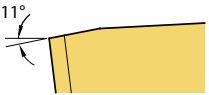
Tipologia	Forma	Tagliente	Caratteristiche
N			<ul style="list-style-type: none"> • Raccomandato per lavorare acciaio e ghisa • Per taglio interrotto e alto avanzamento
S 			<ul style="list-style-type: none"> • Raccomandato per lavorare Inox e HRSA • Tagliente affilato • Per alta velocità e taglio continuo
N (Inclinato) 			<ul style="list-style-type: none"> • Raccomandato per lavorazione di tubi e barre tonde • Materiale da riporto minimizzato

☑ Caratteristiche dell'Inserto Inclinato

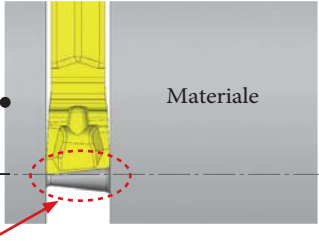
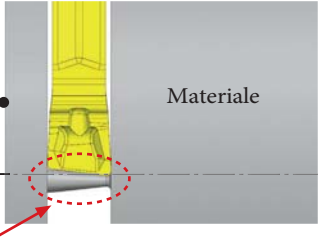
Inserto	Direzione Destra	Direzione Sinistra
Inserto Inclinato	 <p>Parte da tagliare</p> <p>Materiale</p>	 <p>Parte da tagliare</p> <p>Materiale</p>

✓ Parametri di taglio raccomandati _Rompitruciolo N

Materiale				Coppia (N/mm ²)	Durezza Brinell (HB)	Resistenza all'usura ← ● → Tenacità			Scanalatura Troncatura
ISO	Materiale	ISO (DIN)	AISI			Alta velocità e taglio continuo	Taglio continuo e mediamente interrotto	Bassa velocità, taglio continuo e interrotto	
				Grade			N		
				PC8110	PC3035	PC5300	N		
				vc(m/min)			fn(mm/giro)		
P	Acciai non legati	C35	1035	1600	150	-	140	120	0.28
						-	170	150	0.18
						-	200	180	0.08
		C45	1045	1700	170	-	120	100	0.25
						-	150	120	0.15
	Acciai legati	42CrMo4	4140	1700	180	-	180	160	0.08
						-	120	100	0.25
						-	150	120	0.15
		-	4145	2050	350	-	100	80	0.25
						-	130	120	0.15
-	-	-	-	-	150	140	0.08		
M	Austenitici	X5CrNi18-9 (X2CrNi19-11)	304	2000	180	80	-	60	0.20
						130	-	120	0.15
		170	-	160	0.06				
	-	X5CrNiMo17-12-2	316	2000	180	80	-	60	0.20
						130	-	120	0.15
						170	-	160	0.06
K	Ghisa Grigia	250 (GG25)	No35B	1100	245	100	-	80	0.28
						150	-	120	0.18
						200	-	180	0.10
	Ghisa Sferoidale	450-10	80-55-06	1440	230	80	-	70	0.25
						130	-	110	0.15
						180	-	160	0.10

✓ Parametri di taglio raccomandati _Rompitruciolo S

Materiale				Coppia (N/mm ²)	Durezza Brinell (HB)	Resistenza all'usura ← ● → Tenacità		Scanalatura /Troncatura	
ISO	Materiale	ISO (DIN)	AISI			Alta velocità e taglio continuo	Bassa velocità, taglio continuo e interrotto		C/B
				Grade		S			
				PC8110	PC5300	S			
				vc(m/min)		fn(mm/giro)			
M	Austenitici	X5CrNi18-9 (X2CrNi19-11)	304	2000	180	80	60	0.20	
						150	130	0.15	
		180	160	0.06					
	-	X5CrNiMo17-12-2	316	2000	180	80	60	0.20	
						150	130	0.15	
						180	160	0.06	
S	Generici	-	Inconel909	2400	200	65	55	0.15	
						80	70	0.10	
						95	85	0.05	
	Serie Ni	15156-3	Inconel625	2650	250	45	35	0.15	
						60	50	0.10	
						75	65	0.05	
		-	9723	Inconel718	2900	350	30	25	0.15
							40	35	0.10
							50	45	0.05
	Leghe in Titanio	-	B265 (ASTM)	1300	400	45	35	0.15	
						60	50	0.10	
						75	65	0.05	
5832-11		Ti-6Al-4V	1400	950	35	25	0.15		
					50	40	0.10		
65	55	0.05							

✓ Parametri di taglio raccomandati _Rompitruciolo N (Inclinato)

Materiale				Coppia (N/mm ²)	Durezza Brinell (HB)	Resistenza all'usura ← ● → Tenacità			Scanalatura Troncatura					
ISO	Materiale	ISO (DIN)	AISI			Alta velocità e taglio continuo	Taglio continuo, e mediamente interrotto	Bassa velocità, Taglio continuo e interrotto		C/B				
				Grade			fn (mm/giro)							
				PC8110	PC3035	PC5300								
				vc (m/min)										
P	Acciai non legati	C35	1035	1600	150	-		140	120	0.18				
						-	170	150	0.12					
						-	200	180	0.06					
		C45	1045	1700	170	-	120	100	0.18					
						-	150	120	0.12					
	Acciai legati	42CrMo4	4140	1700	180	-	180	160	0.06					
						-	120	100	0.18					
						-	150	120	0.12					
		-	4145	2050	350	-	100	80	0.18					
						-	130	120	0.12					
M	Austenitici	X5CrNi18-9 (X2CrNi19-11)	304	2000	180	80	-	60	0.18					
						130	-	120	0.12					
						170	-	160	0.06					
		X5CrNiMo17-12-2	316	2000	180	80	-	60	0.18					
						130	-	120	0.12					
	Ghisa Grigia	250 (GG25)	No35B	1100	245	100	-	80	0.18					
						150	-	120	0.12					
						200	-	180	0.06					
						Ghisa Duttile	450-10	80-55-06	1440	230	80	-	70	0.18
											130	-	110	0.12
-	-	-	-	-	180	-	160	0.06						

✓ Gamma dei Gradi

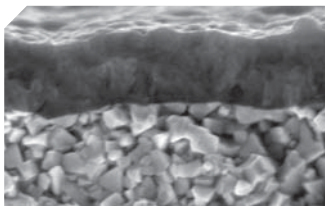

PC3035

P

- Substrato esclusivo per una lavorazione stabile, ha una buona resistenza all'usura nella lavorazione dell'acciaio
 - Nuovo strato TiAlN con eccellente resistenza all'usura e alle alte temperature
 - Resistente alle fratture, assicura una lavorazione stabile nelle scanalature di acciaio

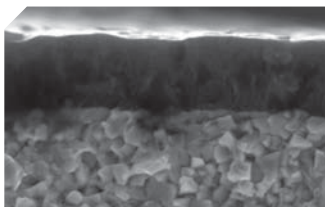

PC5300

P M K S

- Substrato ultra-fine ad alta tenacità, grado universale con rivestimento ad alta durezza e resistente all'usura
 - Nuovo strato TiAlN con eccellente resistenza all'usura e alle alte temperature
 - Substrato ultra-fine con buona resistenza alla scheggiatura e alta tenacità

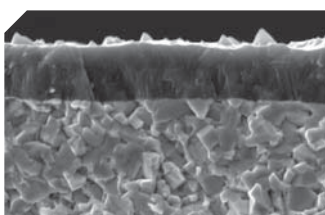

PC8110

M K S

- Substrato adatto alle alte temperature, grado PVD indicato nella lavorazione di materiali difficili da tagliare e ghisa
 - Rivestimento PVD con elevata resistenza alle alte temperature e alle ossidazioni
 - Elevata resistenza all'usura e alla deformazione plastica ad alte temperature

 TEST

Rompitrucciolo N

Materiale Acciaio Legato (42CrMo4), Ø100

Parametri vc(m/min) = 150, fn(mm/giro) = 0.15, ap(mm) = 15, acqua

Inserito/Utensile KSP300-020-N(PC5300) KSPB3026



[Saw Man-X]



[Competitor]

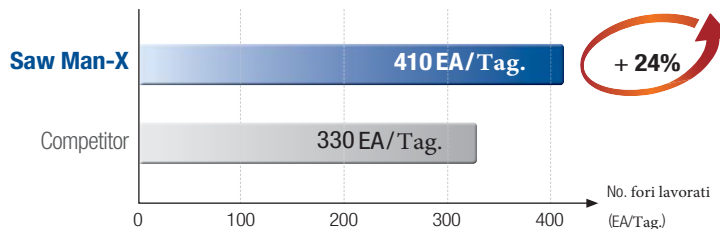

Rompitrucciolo S

Materiale INOX (X5CrNi18-9), Ø100

Parametri vc(m/min) = 120, fn(mm/giro) = 0.15, ap(mm) = 7, acqua

Inserito/Utensile KSP300-02-S(PC5300) KSPB3026



[Saw Man-X]



[Competitor]

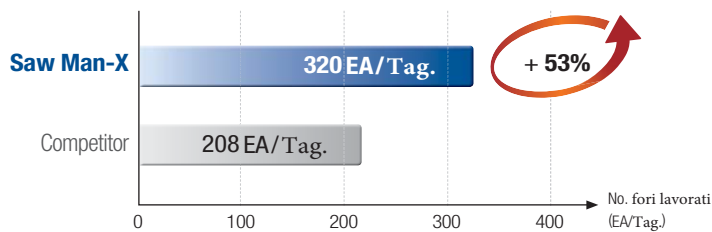

Rompitrucciolo N (Inclinato)

Materiale Acciaio Legato (42CrMo4), Ø100

Parametri vc(m/min) = 120, fn(mm/giro) = 0.12, ap(mm) = 10 (Troncatura), acqua

Inserito/Utensile KSP300R-6D-N(PC5300) KSPB3026



[Saw Man-X]



[Competitor]

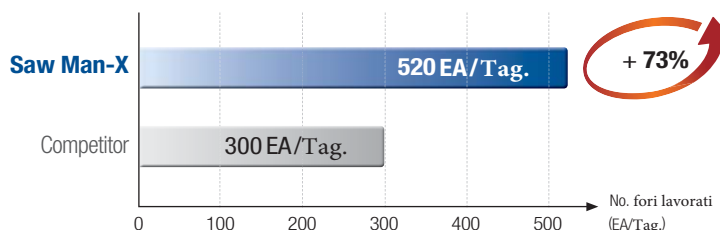

Refrigerante ad alta pressione

Materiale HRSA (9723), Ø50

Parametri vc(m/min) = 50, fn(mm/giro) = 0.10, ap(mm) = 3, acqua

Inserito/Utensile KSP300-020-S(PC5300) KSPB3026-KHP



[Getto interno a 70 bar]



[Getto esterno]

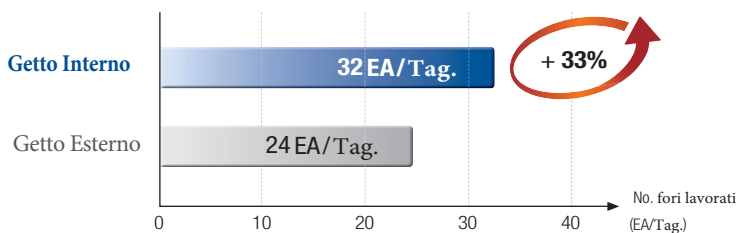

Guida alla scelta dell'Portainserito

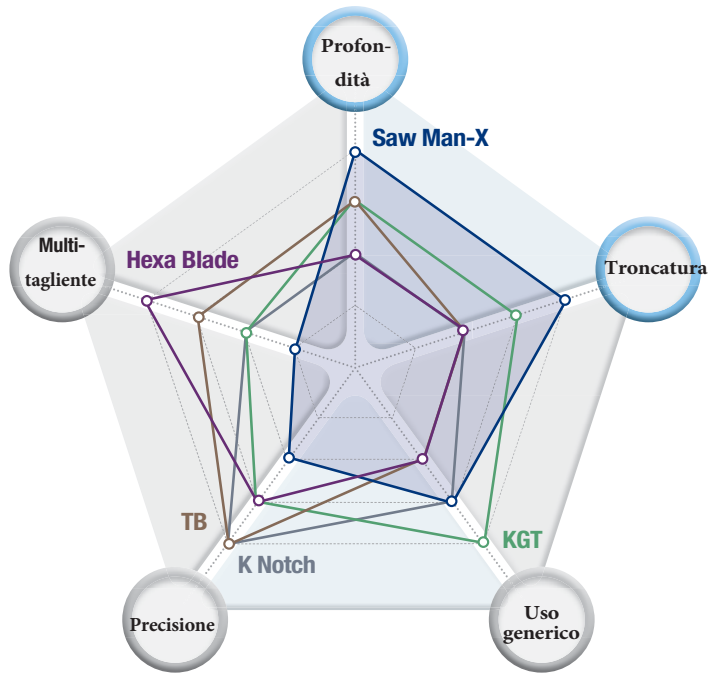

Saw Man-X ^{New}

- Taglio interrotto e alto avanzamento
- Scanalatura profonda



Hexa Blade

- Inserto a 6 taglienti, lavorazione precisa
- Scanalatura precisa



TB

- Lavorazioni precise, inserto a 3 taglienti
- Ideale per macchine automatiche



KGT

- 2 taglienti
- Varie applicazioni
- Uso generico





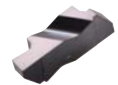

K Notch

- Lavorazioni precise, 2 taglienti
- Serraggio robusto
- Lavorazione precisa







Serie	Profondità	Troncatura	Uso generico	Precisione	Multi-tagliente
Saw Man-X ^{New}	★★★★★	★★★★★	★★★	★★	★
Hexa Blade	★★	★★	★★	★★★★	★★★★★
TB	★★★	★★	★★	★★★★★	★★★
KGT	★★★	★★★	★★★★★	★★★	★★
K Notch	★★	★★	★★★	★★★★★	★★

✓ Larghezza di lavoro e profondità in base al Portainsero

Serie	Larghezza (mm)				Z	Lavorazione				Caratteristiche
	2	4	6	8		Esterna	interna	Frontale	Tronca- tura	
	5	10	20	60						
Ap max (mm)										
Saw Man-X 	2.0	6.0	60.0		1	○			◎	• Bava minimizzata
Hexa Blade 	1.78	4.0	5.0		6	◎			○	• Precisione • Risparmio costi
TB 	1.25	6.0	6.5		3	◎			○	• Precisione • Per macchine automatiche
KGT 	1.5	8.0	28.0		2	◎	○	○	◎	• Varie lavorazioni
K Notch 	0.75	6.3	6.5		2	◎				• Precisione • Serraggio robusto

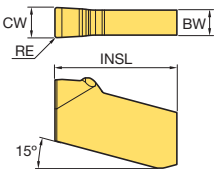
◎: 1° Scelta ○: 2° Scelta

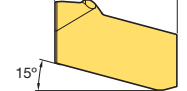
✓ Inserto

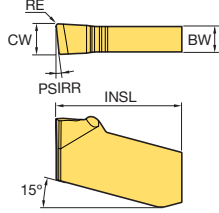
Immagine	Codice	Grado			Dimensioni (mm)					Geometria
		PC3035	PC5300	PC8110	CW	RE	INSL	PSIRR	BW	
	KSP 200-020-N	●	●	●	2.0	0.20	11.0	-	1.6	
	300-020-N	●	●	●	3.0	0.20	12.0	-	2.5	
	400-025-N	●	●	●	4.0	0.25	12.5	-	3.3	
	500-025-N	●	●	●	5.0	0.25	13.5	-	4.3	
	600-035-N	●	●	●	6.0	0.35	14.5	-	5.3	
	KSP 200-020-S	●	●	●	2.0	0.20	11.1	-	1.6	
	300-020-S	●	●	●	3.0	0.20	12.1	-	2.5	
	400-025-S	●	●	●	4.0	0.25	12.6	-	3.3	
	500-025-S	●	●	●	5.0	0.25	13.5	-	4.3	
	600-035-S	●	●	●	6.0	0.35	14.5	-	5.3	
	KSP 200R-6D-N	●	●	●	2.0	0.20	11.1	6°	1.6	
	200L-6D-N	●	●	●	2.0	0.20	11.1	6°	1.6	
	300R-6D-N	●	●	●	3.0	0.20	12.1	6°	2.5	
	300L-6D-N	●	●	●	3.0	0.20	12.1	6°	2.5	
	400R-4D-N	●	●	●	4.0	0.25	12.6	4°	3.3	
	400L-4D-N	●	●	●	4.0	0.25	12.6	4°	3.3	

●: A stock

KSPB (Lama)

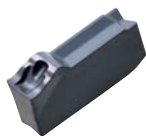

KSP

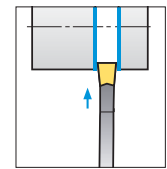
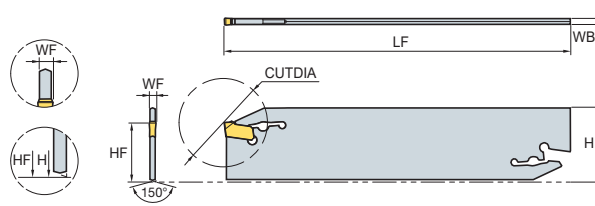

Codice		Stock	Larghezza	CUTDIA	H	WB	LF	HF	WF	Chiave
KSPB	2026	●	2	50	26	1.6	110	21	1.8	CW08
	2032	●	2	52	32	1.6	150	25	1.8	
	3026	●	3	72	26	2.4	110	21	2.7	
	3032	●	3	120	32	2.4	150	25	2.7	
	4026	●	4	72	26	3.2	110	21	3.6	
	4032	●	4	120	32	3.2	150	25	3.6	
	5026		5	80	26	4.0	110	21	4.5	CW10
	5032	●	5	120	32	4.0	150	25	4.5	
	6026		6	120	26	5.2	110	21	5.6	
	6032	●	6	120	32	5.2	150	25	5.6	

●: A stock

SMBB (Portalama)



KSPB□□□□
 SPB□□□(-S)
 KGTB□□□□(S)

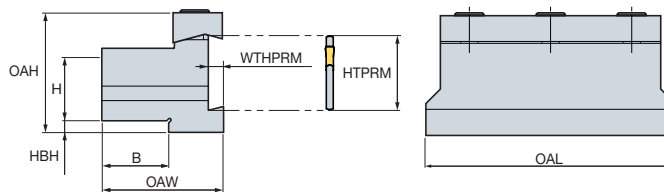

Codice		Stock	H	B	HTPRM	OAL	OAH	HBH	OAW	WTHPRM	Vite	Chiave
SMBB	1626	●	16	12	26	86	43	13	30	5.3	BHA0620	HW50L
	2026	●	20	19	26	86	43	9	38	5.3		
	2032	●	20	19	32	100	50	13	38	5.3		
	2526	●	25	23	26	86	43	4	42	5.3		
	2532	●	25	23	32	110	50	8	42	5.3		
	3232	●	32	30	32	110	54	5	48	5.3		

●: A stock

KSPH (Autocentrante)

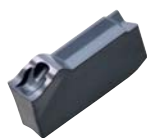

KSP

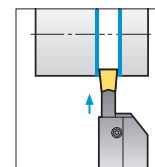
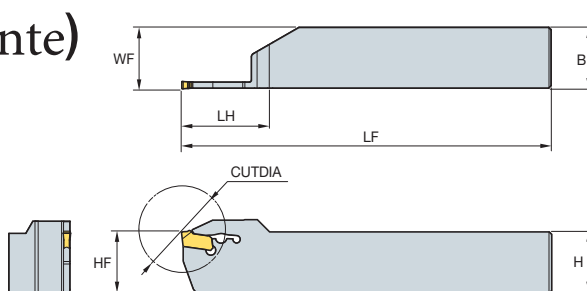

• Insetto destro

(mm)

Codice	Stock		Larghezza	H=(HF)	B	LH	LF	CUTDIA	WF	Chiave
	R	L								
KSPH										
216R/L			2	16	16	31	100	46	16.2	CW08
220R/L			2	20	20	32	120	48	20.2	
225R/L	●		2	25	25	33	150	50	25.2	
316R/L			3	16	16	34	100	52	16.2	
320R/L	●		3	20	20	35	120	54	20.2	
325R/L	●		3	25	25	36	150	56	25.2	
420R/L	●		4	20	20	40	120	64	20.4	
425R/L	●		4	25	25	41	150	66	25.4	
520R/L			5	20	20	45	120	74	20.4	CW10
525R/L	●		5	25	25	46	150	76	25.4	
625R/L	●		6	25	25	46	150	76	25.4	

●: A stock

KSEHR/L (Serraggio a vite)



KSP

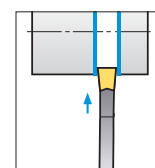
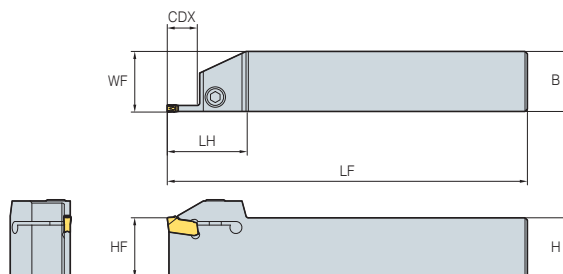

• Insetto destro

(mm)

Codice	Stock		Larghezza	H=(HF)	B	LH	LF	CDX	WF	Vite	Chiave
	R	L									
KSEHR/L											
2020-2-T12			2	20	20	28	125	12	20.2	MHA0512	HW40L
2525-2-T12	●		2	25	25	28	150	12	25.2		
2020-2-T20			2	20	20	36	125	20	20.2		
2525-2-T20	●		2	25	25	36	150	20	25.2		
2020-3-T12			3	20	20	28	125	12	20.25		
2525-3-T12	●		3	25	25	28	150	12	25.25		
2020-3-T25			3	20	20	41	125	25	20.25		
2525-3-T25	●		3	25	25	41	150	25	25.25		
2020-4-T15			4	20	20	36	125	15	20.4	BHA0616	HW50L
2525-4-T15	●		4	25	25	36	150	15	25.4		
2020-4-T25			4	20	20	41	125	25	20.4		
2525-4-T25	●		4	25	25	41	150	25	25.4		
2525-5-T25			5	25	25	41	150	25	25.5		
2525-6-T25			6	25	25	41	150	25	25.5		

●: A stock

KSPB-KHP (Lama) ^{New}

Refrigerante ad alta pressione



KSP

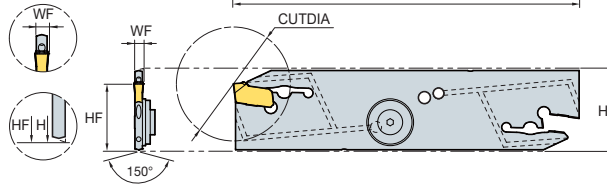

Pressione raccomandata: 70 bar

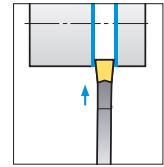

(mm)

Codice	Stock	Larghezza	CUT DIA	H	WB	LF	HF	WF	Chiave	Rondella in rame	Sigillo	Vite Sigillo
KSPB 3026-KHP	●	3	72	26	2.5	110	21	2.75	CW08	HPW1/8PF	FWASMH-D15-V4.5-T1.5	CBSA4-5
4026-KHP	●	4	72	26	3.4	110	21	3.7				

●: A stock

SMBB-KHP (Portalama) ^{New}

Refrigerante ad alta pressione

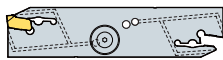

KSPB□□□□-KHP

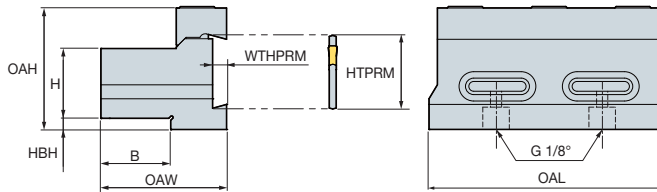

Pressione raccomandata: 70 bar









(mm)

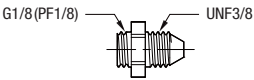

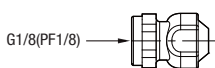
Codice	Stock	H	B	HTPRM	OAL	OAH	HBH	OAW	WTHPRM	Vite	Chiave	O-ring
SMBB 2026-KHP	●	20	20	26	86	43.5	9	38	5	BHA0812	HW60L	NPA14
2526-KHP	●	25	25	26	86	43.5	4	45	5			

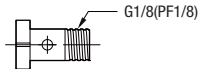
●: A stock

Ricambi

Tipologia	Codice	Immagine	
Adattatore	HPA3/8UNF1/8PF		
Connettore	HPB1/8PF		
Vite Banjo	HPZ1/8PF		
Rondella in Rame	HPW1/8PF		

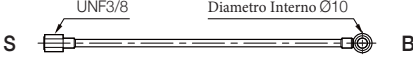
Tubo per alta pressione

	Immagine	Lunghezza	Standard S	Standard B
Attacco dritto/dritto (HPH3/8UNF)		200 mm	UNF3/8	-
		250 mm		
Attacco dritto/banjo (HPH3/8UNF1/8PF)		200 mm	UNF3/8	Diametro Interno Ø10
		250 mm		
Attacco banjo/banjo (HPH1/8PF)		200 mm	-	Diametro Interno Ø10
		250 mm		

Attenzione!

- Utilizzare una chiave adeguata per il serraggio seguendo le specifiche.
- Prestare attenzione alla potenza residua dell'iniezione del refrigerante durante l'uso.
- Fissare completamente le parti prima dell'uso.
- Pulire il tornio prima del fissaggio.
- L'O-ring è incluso nei ricambi. Non è necessario acquistarlo separatamente.

⚠ For the safe metalcutting

- Use safety supplies such as protective gloves to prevent possible injury while touching the edge of tools.
- Use safety glasses or safety cover to hedge possible dangers. Inappropriate usage or excessive cutting condition may lead tool's breakage or even the fragment's scattering.
- Clamp the workpiece tightly enough to prevent its movement while its machining.
- Properly manage the tool change phase because the inordinately used tool can be easily broken under the excessive cutting load or severe wear, and it may threat the operator's safety.
- Use safety cover because chips evacuated during cutting are hot and sharp and may cause burns and cuts. To remove chips safely, stop machining, put on protective gloves, and use a hook or other tools.
- Prepare for fire prevention measures as the use of the non-water soluble cutting oil may cause fire.
- Use safety cover and other safety supplies because the spare parts or the inserts can be pulled out due to centrifugal force while high speed machining.



Head Office: Holystar B/D, 326, Seocho-daero, Seocho-gu, Seoul, 06633, Republic of Korea
Tel: +82-2-522-3181 Fax: +82-2-522-3184, +82-2-3474-4744 Web: www.korloy.com E-mail: sales.khq@korloy.com

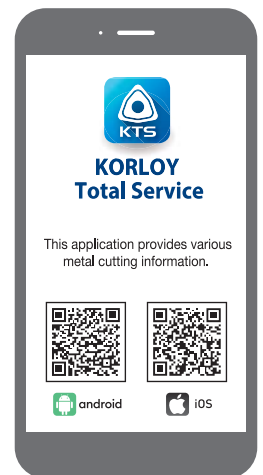

KORLOY AMERICA

620 Maple Avenue, Torrance, CA 90503, USA
Tel: +1-310-782-3800 Toll Free: +1-888-711-0001 Fax: +1-310-782-3885
E-mail: sales.kai@korloy.com

KORLOY INDIA

Plot No. 415, Sector 8, IMT Manesar, Gurgaon 122051, Haryana, India
Tel: +91-124-439-1790 Fax: +91-124-405-0032
E-mail: sales.kip@korloy.com

KORLOY TURKIYE

Serifali Mahallesi, Burhan Sokak NO: 34
Dudullu OSB/Umraniye/Istanbul, 34775, Turkey
Tel: +90-216-415-8874 E-mail: sales.ktl@korloy.com

KORLOY RUSSIA

Premises 1/3, building 3, house 3, per Kapranova, vn.ter.g. municipal district Presnensky, 123242, Moscow, Russia
Tel: +7-495-280-1458 Fax: +7-495-280-1459 E-mail: sales.krc@korloy.com

KORLOY FACTORY INDIA

Plot No. 415, Sector 8, IMT Manesar, Gurgaon 122051, Haryana, India
Tel: +91-124-439-1818 Fax: +91-124-405-0032
E-mail: pro.kim@korloy.com

KORLOY EUROPE

Gablonzer Str. 25-27, 61440 Oberursel, Germany
Tel: +49-6171-27783-0 Fax: +49-6171-27783-59
E-mail: sales.keg@korloy.com

KORLOY BRASIL

Av. Aruana 280, conj.12, WLC, Alphaville, Barueri, CEP06460-010, SP, Brasill
Tel: +55-114-193-3810 Fax: +55-114-193-5837
E-mail: sales.kbl@korloy.com

KORLOY CHILE

Av. Providencia 1650, Office 1009, 7500027
Providencia-Santiago, Chile
Tel: +56-229-295-490 E-mail: sales.kcs@korloy.com

KORLOY MEXICO

Avenida de las Ciencias, No. 3015, Interior 507, Juriquilla Santa Fe, C.P. 76230 Querétaro, Querétaro, Mexico
Tel: +52-442-193-3600 E-mail: sales.kml@korloy.com

