

Nuova fresa per lavorazioni con grandi profondità di taglio

Triple Mill

KORLOY
TECH-NEWS

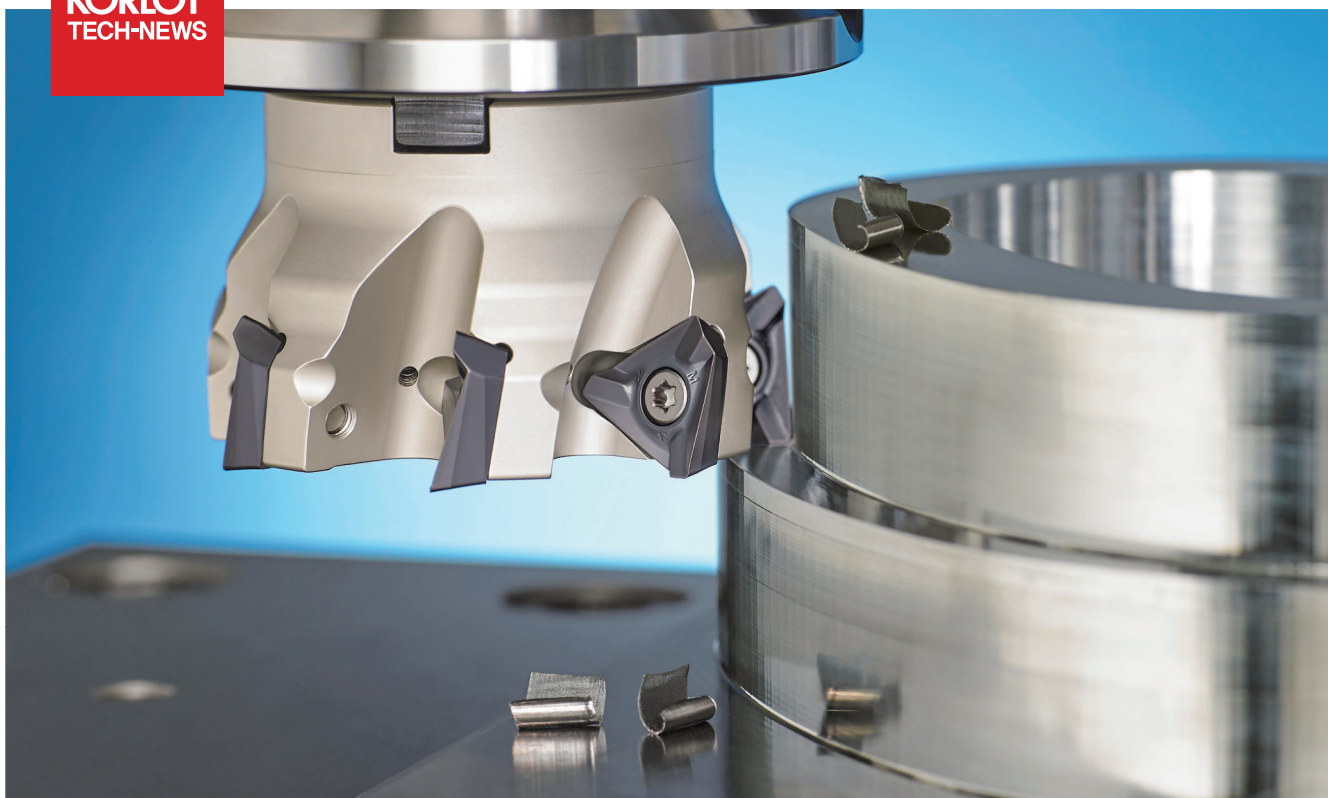

- Inserto positivo con 3 taglienti per lavorazioni con grandi profondità di taglio
- Lavorazione stabile in alto avanzamento grazie all'evacuazione truciolo migliorata e allo spessore dell'inserto maggiorato
- Lavorazioni super precise con minor sforzo di taglio grazie all'elica estesa e al tagliente affilato

Triple Mill

I pezzi di fusione utilizzati per la lavorazione di componenti automobilistici e di stampi metallici di grandi dimensioni presentano superfici irregolari che causano la comparsa di vibrazioni.

La lavorazione di questi materiali è caratterizzata da grandi profondità di taglio spesso irregolari (superfici con taglio interrotto, alto sforzo di taglio, etc). In queste condizioni di lavoro la finitura superficie risulta spesso irregolare, mentre la mancanza di rigidità durante la lavorazione causa un'usura precoce della fresa.

La nuova fresa Triple Mill di KORLOY è in grado di risolvere questi problemi e di realizzare lavorazioni precise anche con grandi asportazioni.

Grazie all'applicazione di un tagliente con un'elevata profondità di taglio (max. 15,5 mm) e un'elica estesa combinati a un rompitruciolo ad alta inclinazione, lo sforzo di taglio è ridotto al minimo e il controllo del truciolo è ottimizzato, azzerando la comparsa di vibrazioni tipiche delle lavorazioni con alte profondità di taglio. In più, il tagliente ad angolo retto assicura una fresatura di alta qualità.

La nuova Triple Mill Korloy è la soluzione alle problematiche legate alle lavorazioni con grandi asportazioni. I gradi disponibili si adattano a ogni applicazione e consentono prestazioni eccellenti aumentando la produttività del cliente.



Risparmio costi

- Inserto con 3 taglienti con alto spessore (Max 15.5mm)

Lavorabilità ottimizzata

- Riduzione dello sforzo di taglio grazie all'elica estesa del tagliente e al rompitruciolo affilato
- Eccellente controllo del truciolo grazie al rompitruciolo ad alta inclinazione

Finitura superficie di alta qualità

- Ottima perpendicolarità e finitura superficie grazie al tagliente ad alta precisione

-Lavorazione stabile

- Serraggio stabile
- Spessore inserto aumentato

Gamma di applicazione

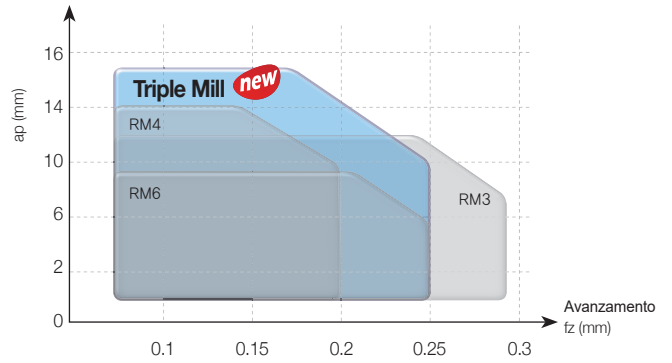
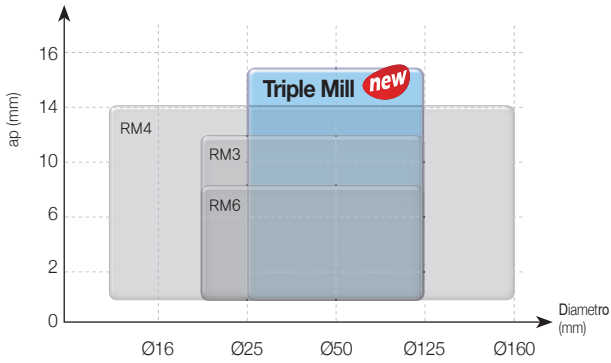

Codifica

【Inserto】

T	N	K	T	20	07	08	P	E	S	R	- MM
Forma T: T	Angolo di spoglia dell'inserto N: 0°	Tolleranza K: K	Intersezione T: T	Lunghezza del lato 20: 20 mm	Spessore 07: 7.0 mm	Raggio 08: R0.8	Angolo di lavoro P: 90°	Angolo del tratto raschiante E: 20°	Preparazione tagliente S: Honing acciaio E: Honing leghe leggere	Direzione R: Destra	Rompitruciolo MM: Uso generico ML: finitura

【Fresa cilindrica】

TPM	S	032	R	- 3	W	32	- 130	- TN11
Triple Mill	Tipo S: cilindrico	Diametro Fresa 032: Ø32 mm	Refrigerante & Direzione R: Con fori, destra NR: Senza fori, sinistra	N° inserti 3: 3 taglienti	Tipo di attacco W: Weldon C: Cilindrico	Diametro di attacco 032: Ø32 mm	Lunghezza totale 130: 130 mm	Inserto TN11: TNKT11

【Fresa a Manicotto】

TPM	C	M	080	- R	27	- 7	- TN20
Triple Mill	Tipo C: Manicotto	Attacco M: Metrico A: Pollici Nessuno: Asia	Diametro Fresa 080: Ø80 mm	Refrigerante & Direzione R: Con fori, destra NR: Senza fori, sinistra	Diametro interno 27: 27 mm	N° inserti 7: 7 taglienti	Inserto TN20: TNKT20

Caratteristiche dell'inserto

- Inserto a tre taglienti per lavorazioni con grandi asportazioni
- Sforzo di taglio ridotto e migliore evacuazione truciolo grazie al rompitruciolo affilato e al tagliente con elica estesa
- Lavorabilità stabile anche in condizioni di taglio elevate grazie alla rigidità del design ottimizzata

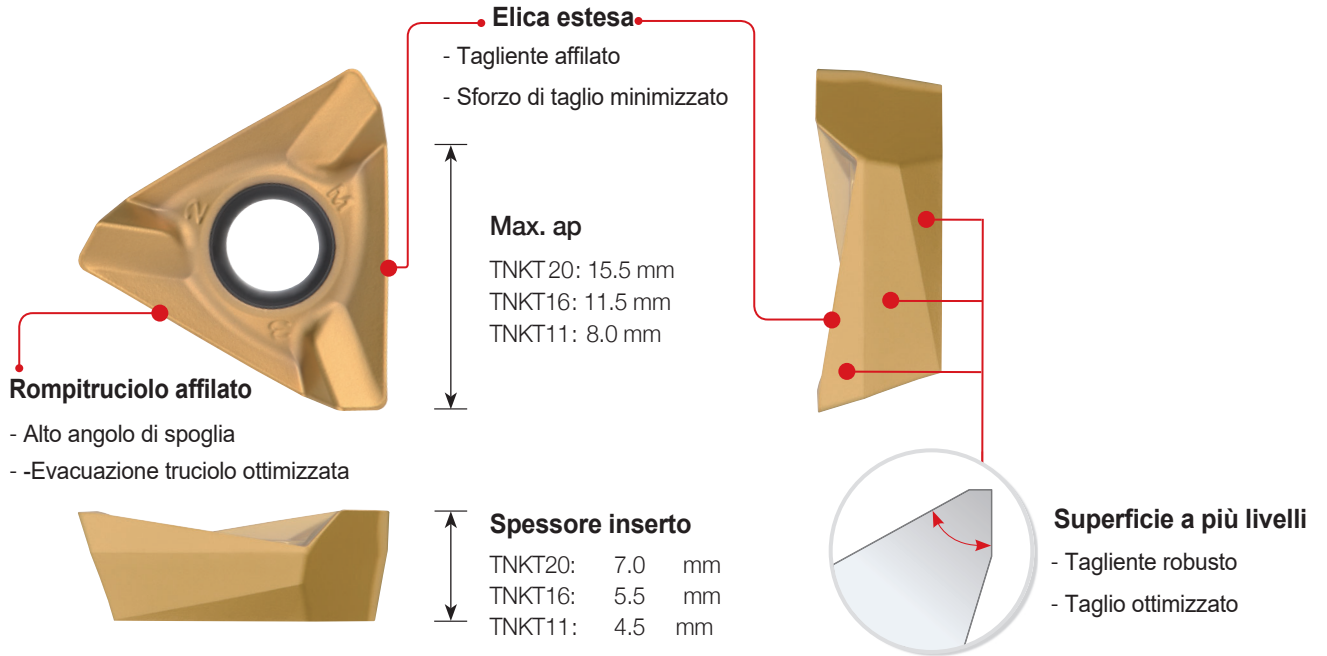

Caratteristiche della Fresa

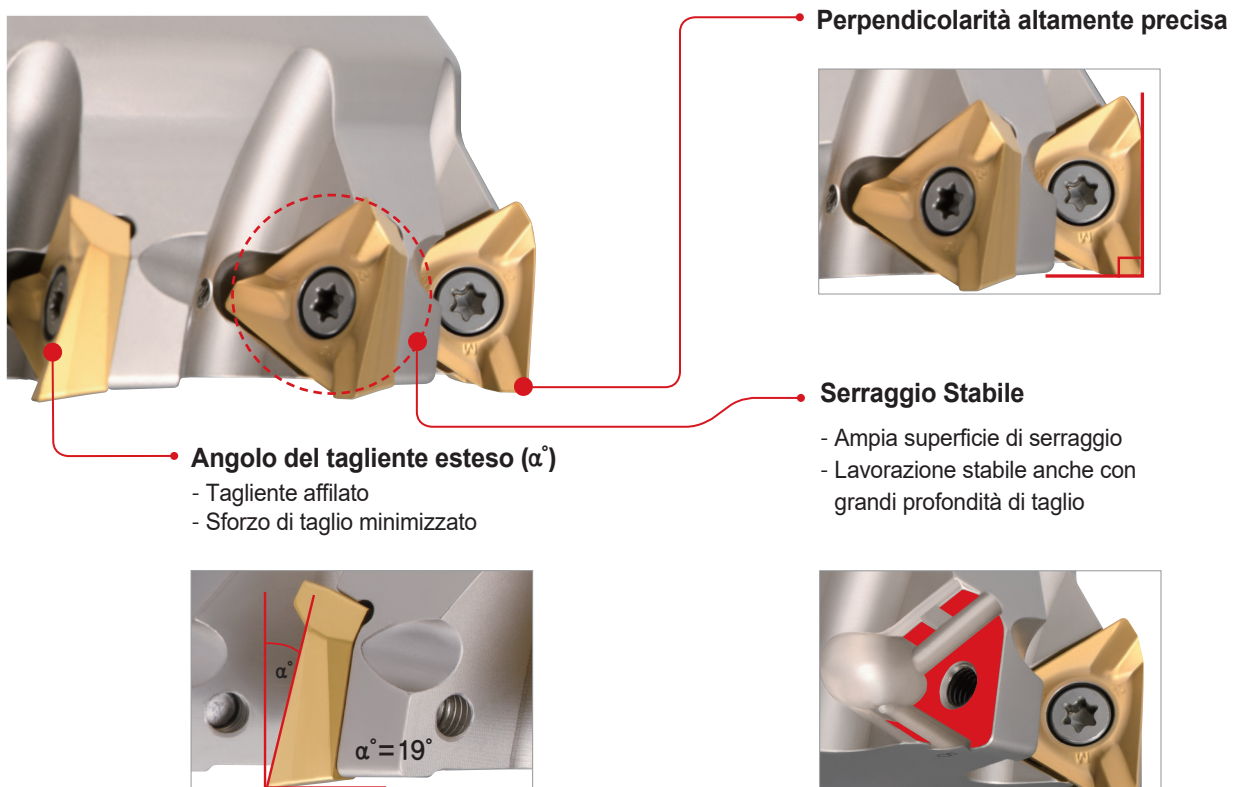

Test sulla Perpendicolarità

- **Materiale** Acciaio legato (SCM440, HB200), 300(L)x200(W)x100(H)
- **Parametri** vc (m/min) = 200, fz (mm/t) = 0.2, ap (mm) = 12 mm x 2Passate (Totale 24 mm), ae (mm) = 5, a secco
- **Inserto/Fresa** Inserto TNKT200708PESR-MM (PC5300) Fresa TPMCM080R-27-7-TN20

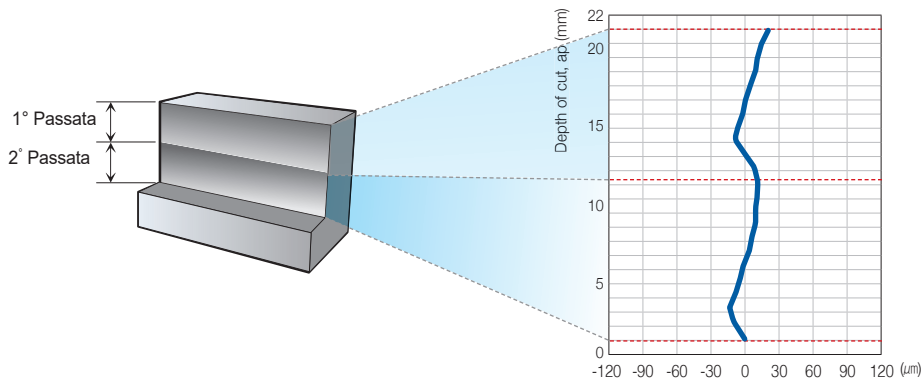

► Errore inferiore a 40 μm .

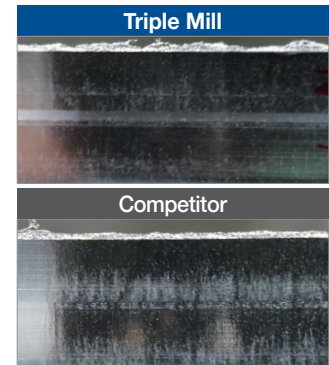

[Finitura superficie a confronto]

Test dell'Usura

- **Materiale** Acciaio legato (SCM440, HB200), 300(L)x200(W)x100(H)
- **Parametri** vc (m/min) = 200, fz (mm/t) = 0.2, ap (mm) = 7, ae (mm) = 10, a secco
- **Fresa/Inserto** Inserto TNKT160608PESR-MM (PC5300) Fresa TPMCM063R-22-6-TN16

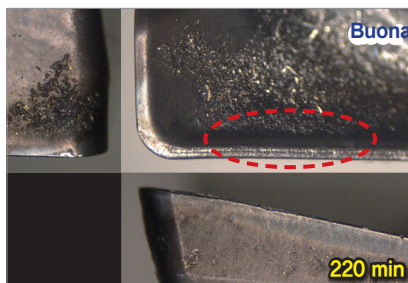

[Triple Mill]

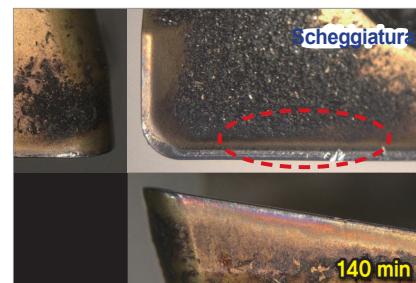

[Competitor]

Test di Finitura

- **Materiale** Acciaio legato (SCM440, HB200), 300(L)x200(W)x100(H)
- **Parametri** vc (m/min) = 200, fz (mm/t) = 0.2, ap (mm) = 7, ae (mm) = 10, a secco
- **Inserto/Fresa** Inserto TNKT160608PESR-MM (PC5300) Fresa TPMCM063R-22-6-TN16

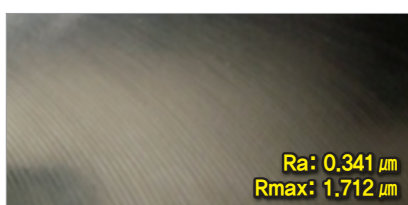

[Triple Mill]

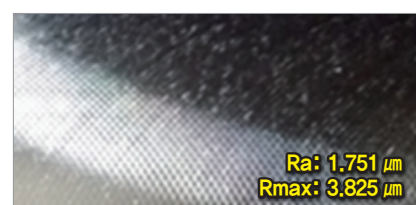

[Competitor]

Guida alla scelta della fresa in base alla Perpendicolarità

Triple Mill

RM3

RM4

RM6

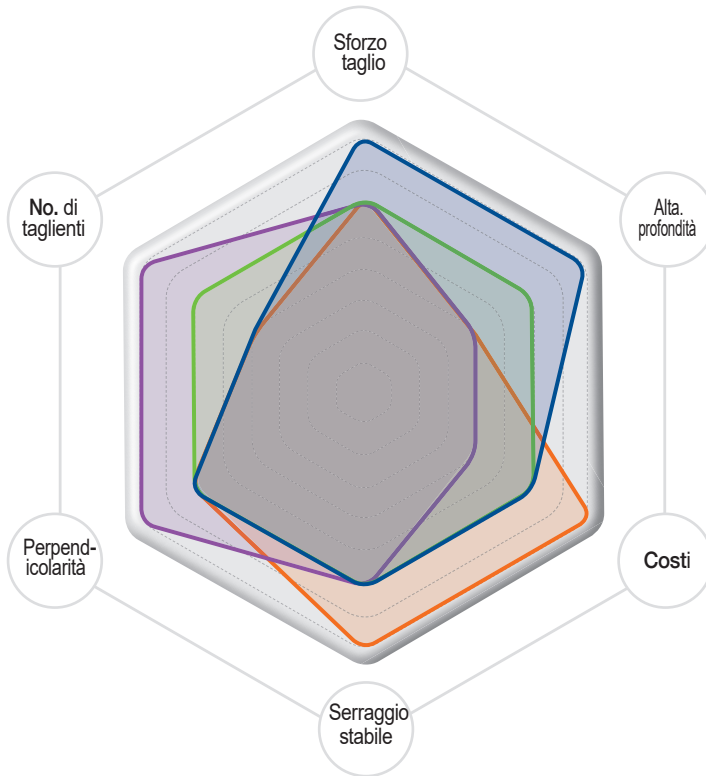

Triple Mill ^{new}

- Basso sforzo di taglio
- Alta profondità

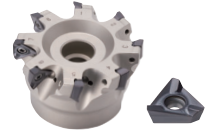

RM3

- Serraggio stabile
- Prezzo competitivo



RM4

- Lavorazioni generiche

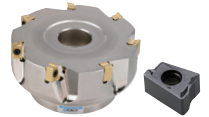

RM6



- Alto n. di taglienti
- Finitura ottimizzata



Serie	Sforzo di taglio	Max. AP	Costi	Serraggio stabile	Perpendicolarità	No. di taglienti
Triple Mill ^{new}	★★★★★	★★★★★	★★★	★★★	★★★	★★
RM3	★★★	★★	★★★★★	★★★★★	★★★	★★
RM4	★★★	★★★	★★★	★★★	★★★	★★★
RM6	★★★	★★★	★★	★★★	★★★★★	★★★★★

Gradi e Rompitrucioli Raccomandati

● 1° scelta

C/B	Tagliente	P				M		K		S	
		Acciai dolci/ Basso cont. carbonio		Acciai legati/ Alto cont. carbonio		Inossidabili		Ghisa		HRSA	
		C/B	Grade	C/B	Grade	C/B	Grade	C/B	Grade	C/B	Grade
ML		-	● PC3700 ○ PC5300 ○ PC5400	-	● PC3700 ○ PC5300 ○ PC5400	●	● PC5300 ○ PC5400 ○ PC9540	-	● PC6510 ○ PC5300 ○ PC5400	●	● UPC845 ○ UNC840 ○ PC5300 ○ PC5400
MM		●	● PC3700 ○ PC5300 ○ PC5400	●	● PC3700 ○ PC5300 ○ PC5400	-	● PC5300 ○ PC5400 ○ PC9540	●	● PC6510 ○ PC5300 ○ PC5400	-	● UPC845 ○ UNC840 ○ PC5300 ○ PC5400

Parametri Raccomandati

Materiale	Grado	Velocità di taglio vc(m/min)	TNKT11		TNKT16		TNKT20	
			fz (mm/t)	Max. ap (mm)	fz (mm/t)	Max. ap (mm)	fz (mm/t)	Max. ap (mm)
P Acciaio	PC3700	160-270	0.25-0.1	8.0	0.25-0.1	11.5	0.25-0.1	15.5
	PC5300	140-240	0.25-0.1	8.0	0.25-0.1	11.5	0.25-0.1	15.5
M Inox	PC5300	90-150	0.2-0.05	8.0	0.2-0.05	11.5	0.2-0.05	15.5
	PC5400	70-120	0.2-0.05	8.0	0.2-0.05	11.5	0.2-0.05	15.5
	PC9540	70-120	0.2-0.05	8.0	0.2-0.05	11.5	0.2-0.05	15.5
K Ghisa	PC6510	150-250	0.3-0.1	8.0	0.3-0.10	11.5	0.3-0.1	15.5
S HRSA	PC5300	20-50	0.15-0.05	8.0	0.15-0.05	11.5	0.15-0.05	15.5
	UPC845	30-50	0.15-0.05	8.0	0.15-0.05	11.5	0.15-0.05	15.5
	UNC840	20-40	0.15-0.05	8.0	0.15-0.05	11.5	0.15-0.05	15.5

※ I dati riportati si riferiscono a condizioni di lavoro generiche e possono essere modificati fino a una velocità di 350m/min e un avanzamento al dente di 0.3mm/t in base alle condizioni di lavoro dell'utilizzatore.

Inserto

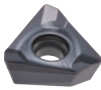
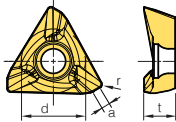
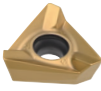
Inserto	Descrizione	Rivestimento						Dimensione (mm)				Geometria
		PC3700	PC6510	PC9540	PC5300	PC5400	UNC840	UPC845	d	t	r	
	TNKT 110508PEER-ML	●			●			8.0	4.500	0.8	1.3	
	160608PEER-ML	●			●			11.7	5.500	0.8	1.5	
	200708PEER-ML	●			●			14.5	7.000	0.8	2.0	
	TNKT 110508PESR-MM	●			●			8.0	4.531	0.8	1.3	
	160608PESR-MM	●			●			11.7	5.531	0.8	1.5	
	200708PESR-MM	●			●			14.5	7.031	0.8	2.0	

●: A stock

TPMCM-TN16

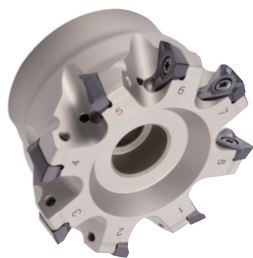

• AR: 10°
• RR: -11°~-13.5°

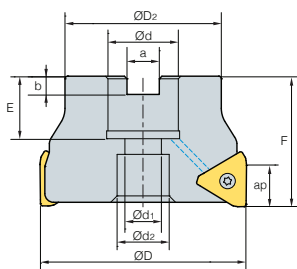

Fig. 1

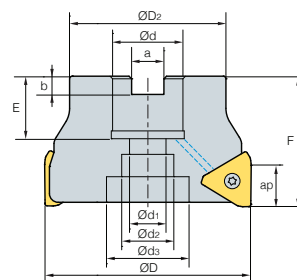

Fig. 2

(mm)

Codice	Stock	ØD	ØD2	Ød	Ød1	Ød2	Ød3	a	b	E	F	ap	kg	Inserto	Fig.
TPMCM 050R-22-4-TN16		50	42	22	11	18	-	10.4	6.3	21	40	11.5	0.26	TNKT16	1
050R-22-5-TN16	●	50	42	22	11	18	-	10.4	6.3	21	40	11.5	0.26		1
063R-22-4-TN16		63	50	22	11	18	-	10.4	6.3	21	40	11.5	0.50		1
063R-22-6-TN16	●	63	50	22	11	18	-	10.4	6.3	21	40	11.5	0.48		1
080R-27-6-TN16		80	60	27	14	20	-	12.4	7	24	50	11.5	0.99		1
080R-27-8-TN16	●	80	60	27	14	20	-	12.4	7	24	50	11.5	0.99		1
100R-32-8-TN16		100	70	32	18	28	45	14.4	8	28	63	11.5	1.85		2
100R-32-10-TN16	●	100	70	32	18	28	45	14.4	8	28	63	11.5	1.83		2
125R-40-12-TN16		125	90	40	22	32	54	16.4	9	30	63	11.5	3.12		2
125R-40-14-TN16	●	125	90	40	22	32	54	16.4	9	30	63	11.5	3.10		2

●: A stock

Inserti disponibili

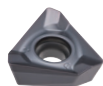

TNKT-ML

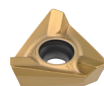

TNKT-MM

Codice	Rivestimento						
	PC3700	PC6510	PC9540	PC5300	PC5400	UNC840	UPC845
TNKT 160608PEER-ML	●			●			
160608PESR-MM	●			●			

●: A stock

Attacchi disponibili

Codice	Ød	Attacchi disponibili
TPMCM 050R-22-□-TN□□	22	BT□□-FMC22-□□
063R-22-□-TN□□		
080R-27-□-TN□□	27	BT□□-FMC27-□□
100R-32-□-TN□□	32	BT□□-FMC32-□□
125R-40-□-TN□□	40	BT□□-FMC40-□□

Ricambi

Specifiche	Ricambi	Vite	Cacciavite
	Ø50~Ø125		FTKA0410

TPMCM-TN20

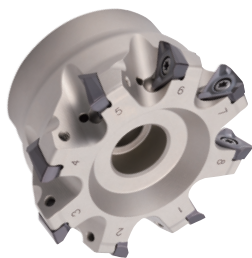

• AR: 10°
• RR: -10.5°~-14°

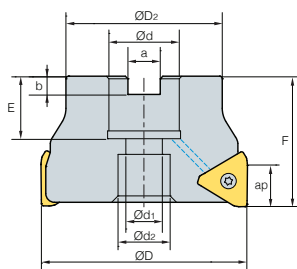

Fig. 1

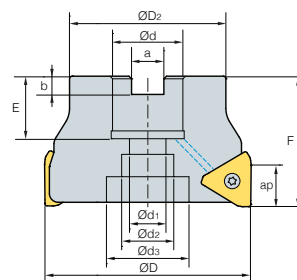

Fig. 2

(mm)

Codice	Stock		ØD	ØD2	Ød	Ød1	Ød2	Ød3	a	b	E	F	ap		Inserto	Fig.
TPMCM 063R-22-5-TN20	●	5	63	50	22	11	18	-	10.4	6.3	21	50	15.5	0.57	TNKT20	1
063R-22-6-TN20	●	6	63	50	22	11	18	-	10.4	6.3	21	50	15.5	0.58		1
080R-27-5-TN20	●	5	80	60	27	14	20	-	12.4	7	24	50	15.5	0.92		1
080R-27-7-TN20	●	7	80	60	27	14	20	-	12.4	7	24	50	15.5	0.86		1
100R-32-7-TN20	●	7	100	70	32	18	28	45	14.4	8	28	63	15.5	1.79		2
100R-32-9-TN20	●	9	100	70	32	18	28	45	14.4	8	28	63	15.5	1.68		2
125R-40-8-TN20		8	125	90	40	22	32	52	16.4	9	30	63	15.5	3.08		2
125R-40-11-TN20		11	125	90	40	22	32	52	16.4	9	30	63	15.5	2.99		2

●: A stock

Inserti disponibili

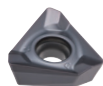

TNKT-ML

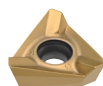

TNKT-MM

Codice	Rivestimento						
	PC3700	PC6510	PC9540	PC5300	PC5400	UNC840	UPC845
TNKT 200708PEER-ML	●			●			
200708PESR-MM	●			●			

●: A stock

Attacchi disponibili

Codice	Ød	Attacchi disponibili
TPMCM 063R-22-□-TN□□	22	BT□□-FMC22-□□
080R-27-□-TN□□	27	BT□□-FMC27-□□
100R-32-□-TN□□	32	BT□□-FMC32-□□
125R-40-□-TN□□	40	BT□□-FMC40-□□

Ricambi

Specifiche	Ricambi	Vite	Cacciavite
	Ø63~Ø125		FTGA0511-P

TPMS-TN11

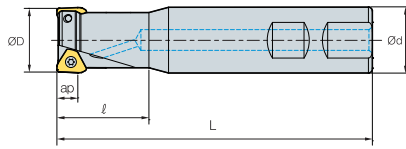

Fig. 1

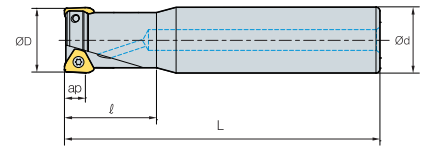

Fig. 2



AA
90°

• AR: 8°~10°
• RR: -14°~-15°

(mm)

Codice	Stock		ØD	Ød	ℓ	L	ap	kg	Inserto	Fig.
TPMS 025R-2W25-120-TN11		2	25	25	35	120	8.0	0.37	TNKT11	1
025R-2C25-200-TN11		2	25	25	35	200	8.0	0.65		2
025R-3W25-120-TN11	●	3	25	25	35	120	8.0	0.36		1
025R-3C25-200-TN11	●	3	25	25	35	200	8.0	0.64		2
032R-2W32-130-TN11		2	32	32	40	130	8.0	0.71		1
032R-2C32-200-TN11		2	32	32	40	200	8.0	1.12		2
032R-3W32-130-TN11		3	32	32	40	130	8.0	0.70		1
032R-3C32-200-TN11		3	32	32	40	200	8.0	1.14		2
032R-4W32-130-TN11	●	4	32	32	40	130	8.0	0.70		1
032R-4C32-200-TN11	●	4	32	32	40	200	8.0	1.11		2
040R-4W40-130-TN11		4	40	40	40	130	8.0	1.12		1
040R-5W40-130-TN11	●	5	40	40	40	130	8.0	1.11		1

●: A stock

Inserti disponibili

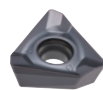

TNKT-ML

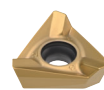

TNKT-MM

Codice	Rivestimento						
	PC3700	PC6510	PC9540	PC5300	PC5400	UNC840	UPC845
TNKT 110508PEER-ML	●			●			
110508PESR-MM	●			●			

●: A stock

Ricambi

Specifiche	Ricambi	Vite	Cacciavite
	Ø25-Ø40		FTKA0307

TPMS-TN16

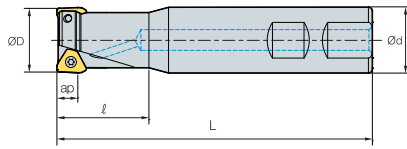

Fig. 1

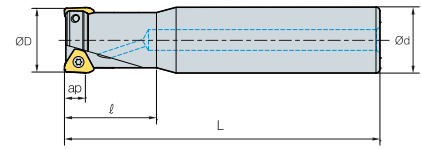

Fig. 2



AA
90°
• AR: 10°
• RR: -13.5°

(mm)

	Codice	Stock		ØD	Ød	l	L	ap		Inserto	Fig.
TPMS	032R-2W32-130-TN16	●	2	32	32	40	130	11.5	0.68	TNKT16	1
	032R-2C32-200-TN16		2	32	32	40	200	11.5	1.10		2
	040R-3W40-130-TN16		3	40	40	40	130	11.5	1.09		1
	040R-3C40-200-TN16		3	40	40	40	200	11.5	1.75		2
	040R-4W40-130-TN16	●	4	40	40	40	130	11.5	1.08		1

●: A stock

Inserti disponibili

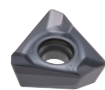

TNKT-ML

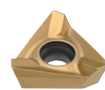

TNKT-MM

Codice	Rivestimento						
	PC3700	PC6510	PC9540	PC5300	PC5400	UNC840	UPC845
TNKT 160608PEER-ML	●			●			
160608PESR-MM	●			●			

●: A stock

Ricambi

Specifiche	Ricambi	Vite	Cacciavite
	Ø32-Ø40		FTKA0410

The logo consists of a stylized 'P' and 'C' in black with a blue gradient, followed by the word 'PALEARICARLO' in a bold, black, sans-serif font.

PALEARICARLO



Via Asmara, 7
21052 Busto Arsizio - Italia
T+39 0331 350 000
ordini@palearicarlo.com
www.palearicarlo.com