

RM6



Double-Sided 6-Corner Shoulder Milling Tool

Milling tool series for high quality surface finish and cost efficiency

- ▣ **Higher Productivity**

Designed to provide high speed and feed improves chip removal rates

- ▣ **Improved Perpendicularity**

True perpendicular milling

- ▣ **Superior Clamping Stability**

Powerful clamping thanks to strong clamping screws and 3-side flank supporting system



Double-Sided 6-Corner Shoulder Milling Tool

RM6

Mold making companies are required to keep up with the demands of the accelerated development of Industrial structures.

RM6, KORLOY's new Rich Mill Series for shouldering responds to these demands by employing double-sided inserts with six perpendicular corners to achieve cost efficiency.

It features strong clamping screws, 3-side supporting system, and wide clamping areas which enable powerful clamping force. This facilitates stable machining at high speed and feed, and delivers higher productivity.

Wide minor cutting edges and optimized multi-stepped relief surfaces of the RM6 provide exceptional bottom surface finish. The RM6 achieves perpendicularity and improved flank surface finish. The chip breaker design high rake and high helix angle were applied to the inserts for stable cutting performance in hard-to-cut materials or high hardened workpieces, achieving an increase in tool life.

KORLOY's RM6 is one of the most advanced shouldering solutions available to meet the demand of the mold making market today.

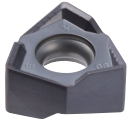

Insert



Cutter



Shank

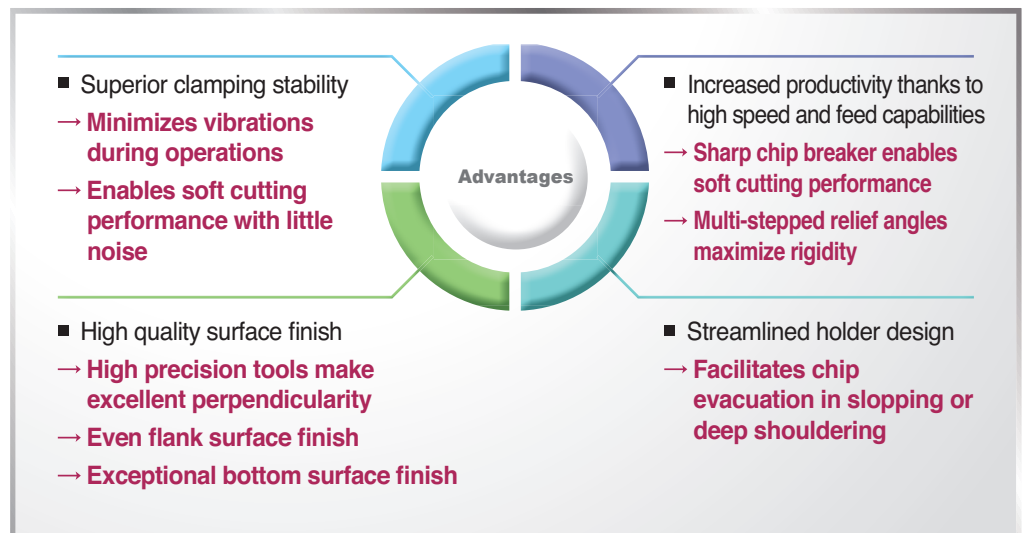

Code System

[Insert shape]

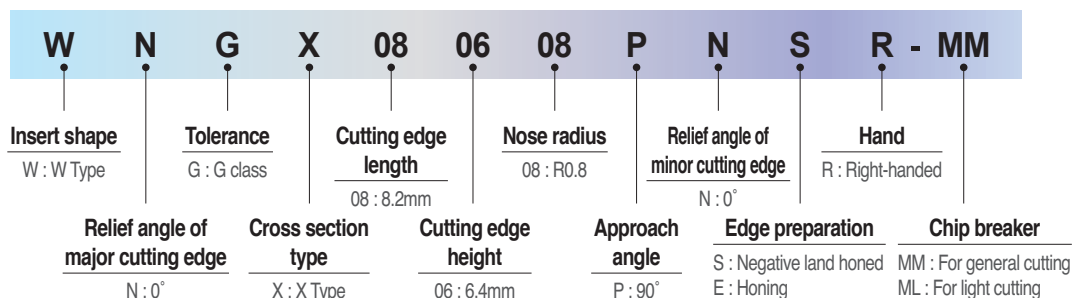

Code System

[Shank Type]

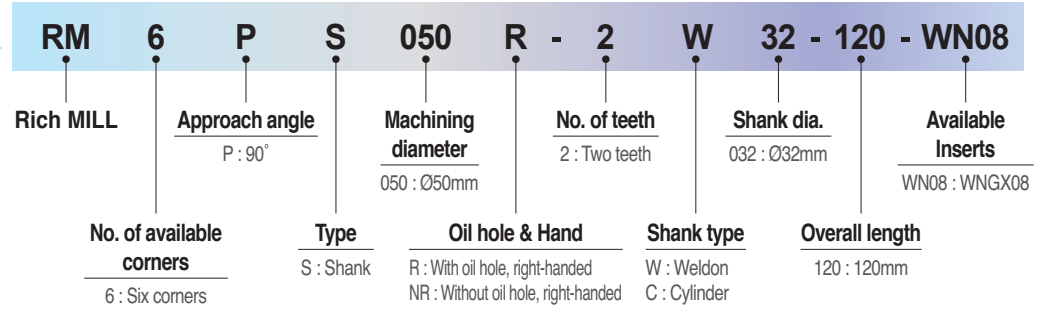

[Cutters type]

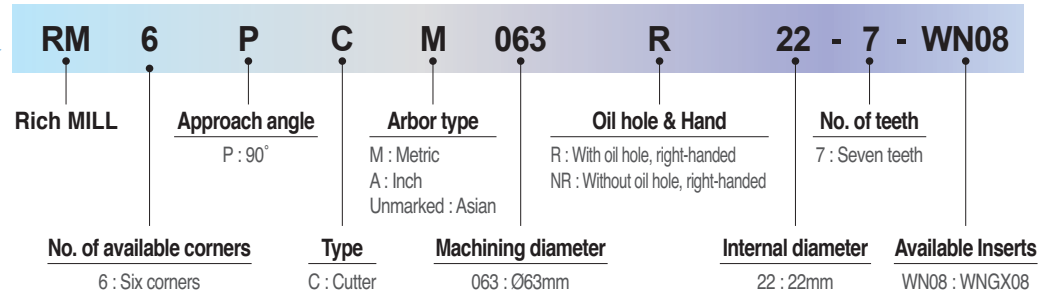

RM6 Features

- **Stable clamping** - 3 clamping surfaces on the side and strong clamping screws
→ Improves cutting stability
- **High quality results** - High precision, excellent perpendicularity, outstanding surface finish on the flank, accurate tolerance
- **High productivity** - High rake angle and sharp cutting edges for lower cutting resistance
→ Ideal for high speed and high feed machining

Insert Features

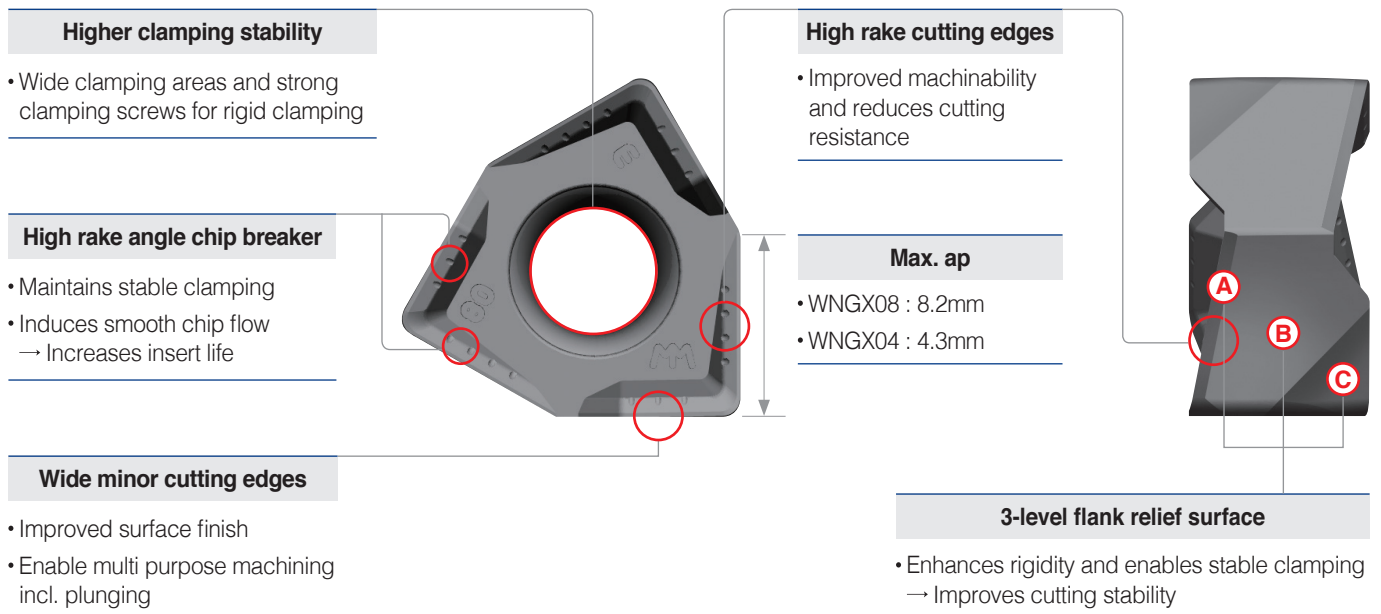

⇒ Cutter Features

- 3-side supporting system, strong clamping screws, and wide seat areas
 - **Improve clamping stability**
 - **Reduce tool vibrations and cutting resistance**
- Optimized H/D design with curved surface for smooth chip flow
 - **Facilitates chip evacuation in slopping or deep shouldering**

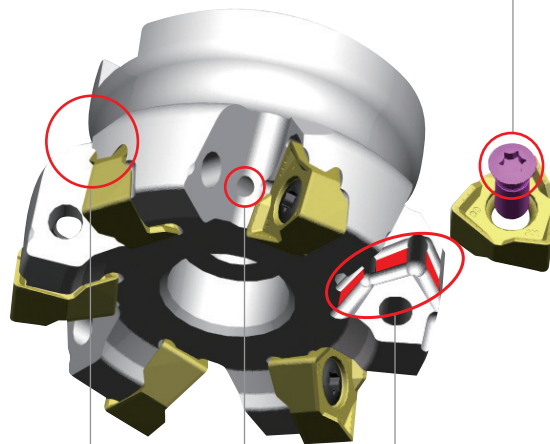

Strong clamping screws

- Strong clamping screws enable rigid clamping

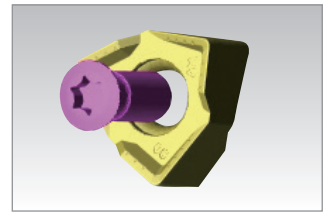

Streamlined holder design

- Improved chip evacuation in deep shouldering and slotting

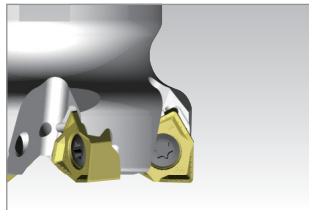

Through coolant system

- Improved chip flow and tool life thanks to insert cooling

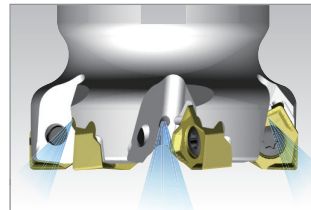

3-side supporting system

- Stable tool life



⇒ Chip Breaker Features

- Chip breaker **MA**

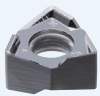

- Chip breaker **ML**

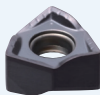

- Chip breaker **MM**

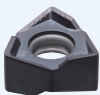

| Chip breaker | Cutting edge | Application | Features |
|--------------|--------------|---------------------|---|
| MA | | For aluminum | <ul style="list-style-type: none"> ■ MA : Milling Aluminum ■ Sharp cutting edges for excellent cutting performance in aluminum machining ■ Buffed surface for excellent chip flow and welding resistance |
| ML | | For light cutting | <ul style="list-style-type: none"> ■ ML : Milling Light ■ Chip breaker design of low cutting resistance, ideal for light cutting and machining hard-to-cut materials ■ Excellent tool life and quality results |
| MM | | For general cutting | <ul style="list-style-type: none"> ■ MM : General shouldering operations ■ Chip breaker design ideal for general shoulder milling and most applications |

➔ Performance Evaluation

- Workpiece 42CrMo4(DIN), SCM440(KS), 4140(AISI), 300(L)x200(W)x100(H), Steel rectangular tube
- Cutting conditions $vc(m/min)=250$, $fz(mm/t)=0.2$, $ap(mm)=4$, $ae(mm)=10$, Dry
- Machining method Facing
- Tools Insert WNGX080608PNSR-MM(PC5300) Holder RM6PCM063R-22-6-WN08

• Chipping resistance has improved thanks to stable clamping even at high speed

→ **Minimized unexpected tool breakage**

• Sharp cutting edges and streamlined chip breaker design

→ **Minimized cutting resistance**

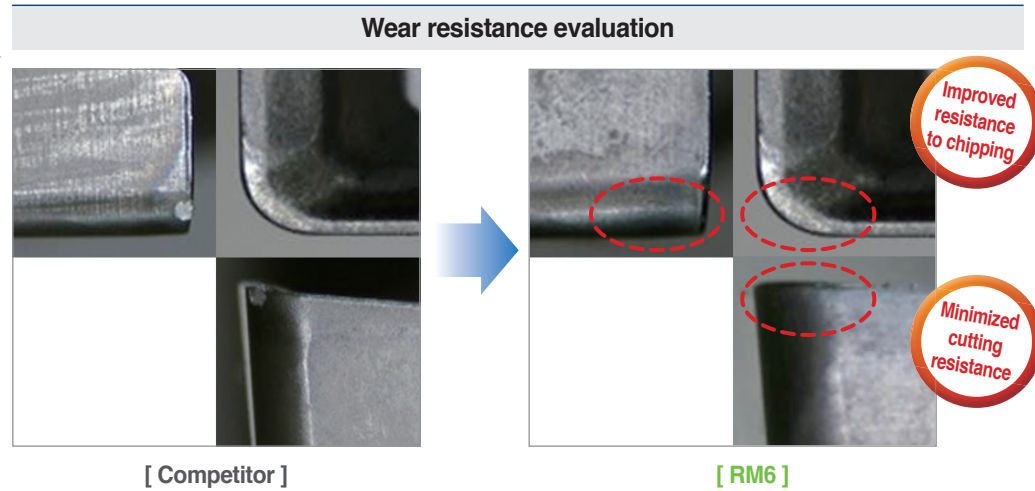

➔ Perpendicularity Evaluation

- Workpiece C45(ISO), SM45C(KS), 1045(AISI), 300(L)x200(W)x100(H), Steel rectangular tube
- Cutting conditions $vc(m/min)=150$, $fz(mm/t)=0.15$, $ap(mm)=7$, $ae(mm)=5$, Dry
- Machining method Perpendicularity, flank surface finish, and unevenness were measured after three passes of 7mm each, and 21mm in total
- Tools Insert WNGX080608PNSR-MM(PC5300) Holder RM6PCM063R-22-6-WN08

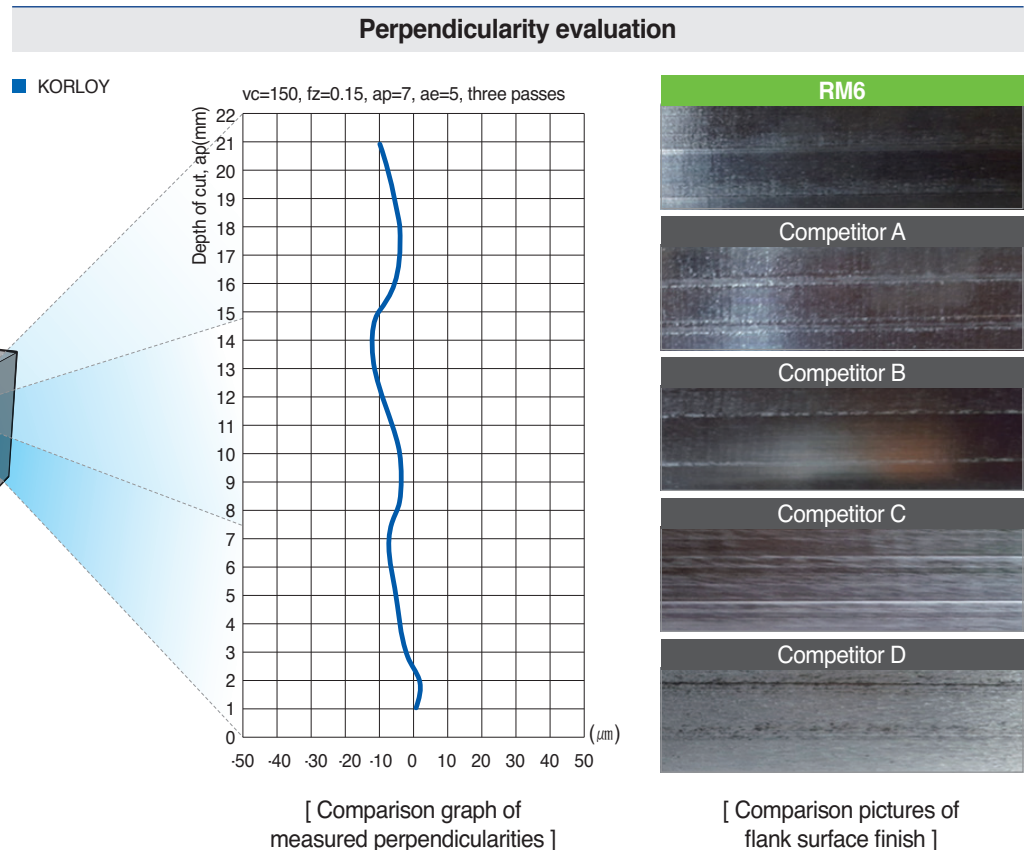

⇒ Application Examples

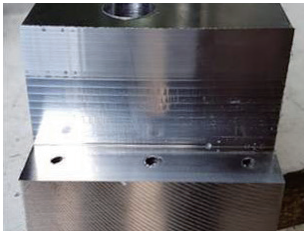

Carbon steel [C45(ISO), HB180]

- Cutting conditions vc(m/min)=250, fz(mm/t)=0.12, ap(mm)=7, ae(mm)=2, Dry
- Machining method Shouldering
- Tools Insert WNGX080608PNSR-MM(PC5300)
Holder RM6PS032R-2W32-120-WN08



➔ 50% longer tool life compared to the competitor



Cold forged tool steel [X100CrMoV5 1(DIN), HB255]

- Cutting conditions vc(m/min)=235, fz(mm/t)=0.28, ap(mm)=2, ae(mm)=5, Dry
- Machining method Shouldering
- Tools Insert WNGX080608PNER-ML(PC5300)
Holder RM6PCM063R-22-6-WN08



➔ 64% longer tool life compared to the competitor



Cast iron [600-3(ISO), HB230]

- Cutting conditions vc(m/min)=226, fz(mm/t)=0.19, ap(mm)=1, ae(mm)=75, Dry
- Machining method Facing
- Tools Insert WNGX080608PNER-ML(PC5400)
Holder RM6PCM080R-27-7-WN08



➔ 20% longer tool life compared to the competitor



Grade Guideline per Workpiece Type

| Cutting conditions | | P | | M | K | N |
|--------------------|---------------------|--------------|-------------|-----------------|-----------|-------------------|
| | | Carbon steel | Alloy steel | Stainless steel | Cast iron | Non-ferrous metal |
| Shape | 1st recommended | MM | MM | ML | ML | MA |
| | 2nd recommended | ML | ML | - | MM | MA |
| Grade | High speed milling | PC3600 | PC3600 | PC5300 | PC6510 | H01 |
| | General milling | PC5400 | PC5300 | PC5400 | PC5300 | H01 |
| | Interrupted milling | PC5400 | PC5400 | PC5400 | PC5400 | H01 |

Recommended Cutting Conditions

WNGX04

| Workpiece | Grade | WNGX040304PNSR-MM | | | WNGX040304PNER-ML | | | WNGX040304PNFR-MA | | |
|---------------------|--------|-------------------|-----------|-------------|-------------------|-----------|-------------|-------------------|-----------|-------------|
| | | vc (m/min) | fz (mm/t) | max. ap(mm) | vc (m/min) | fz (mm/t) | max. ap(mm) | vc (m/min) | fz (mm/t) | max. ap(mm) |
| P Steel | PC3600 | 160~270 | 0.25~0.05 | 4.3 | 160~270 | 0.20~0.05 | 4.3 | - | - | - |
| | PC5300 | 150~240 | 0.25~0.05 | | 150~240 | 0.25~0.05 | | - | - | - |
| | PC5400 | 130~210 | 0.25~0.05 | | 130~210 | 0.25~0.05 | | - | - | - |
| M Stainless steel | PC5300 | 90~150 | 0.20~0.05 | 4.3 | 90~150 | 0.10~0.05 | 4.3 | - | - | - |
| | PC5400 | 70~120 | 0.20~0.05 | | 70~120 | 0.10~0.05 | | - | - | - |
| K Cast iron | PC6510 | 140~230 | 0.30~0.08 | 4.3 | 140~230 | 0.25~0.08 | 4.3 | - | - | - |
| | PC5300 | 120~200 | 0.30~0.08 | | 120~200 | 0.25~0.08 | | - | - | - |
| N Non-ferrous metal | H01 | - | - | - | - | - | - | 500~1000 | 0.2~0.05 | 4.3 |

* The above data refer to general cutting conditions and can be adjustable up to 300m/min and 0.4mm/t depending on user environment.

WNGX08

| Workpiece | Grade | WNGX080608PNSR-MM | | | WNGX080608PNER-ML | | | WNGX080608PNFR-MA | | |
|---------------------|--------|-------------------|-----------|-------------|-------------------|-----------|-------------|-------------------|-----------|-------------|
| | | vc (m/min) | fz (mm/t) | max. ap(mm) | vc (m/min) | fz (mm/t) | max. ap(mm) | vc (m/min) | fz (mm/t) | max. ap(mm) |
| P Steel | PC3600 | 160~270 | 0.25~0.05 | 8.2 | 160~270 | 0.20~0.05 | 8.2 | - | - | - |
| | PC5300 | 150~240 | 0.25~0.05 | | 150~240 | 0.25~0.05 | | - | - | - |
| | PC5400 | 130~210 | 0.25~0.05 | | 130~210 | 0.25~0.05 | | - | - | - |
| M Stainless steel | PC5300 | 90~150 | 0.20~0.05 | 8.2 | 90~150 | 0.10~0.05 | 8.2 | - | - | - |
| | PC5400 | 70~120 | 0.20~0.05 | | 70~120 | 0.10~0.05 | | - | - | - |
| K Cast iron | PC6510 | 140~230 | 0.30~0.08 | 8.2 | 140~230 | 0.25~0.08 | 8.2 | - | - | - |
| | PC5300 | 120~200 | 0.30~0.08 | | 120~200 | 0.25~0.08 | | - | - | - |
| N Non-ferrous metal | H01 | - | - | - | - | - | - | 500~1000 | 0.2~0.05 | 8.2 |

* The above data refer to general cutting conditions and can be adjustable up to 300m/min and 0.4mm/t depending on user environment.

Ramping

1. Ramping

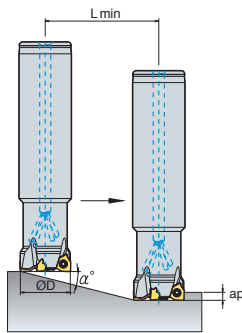

2. Helical cutting for blind holes

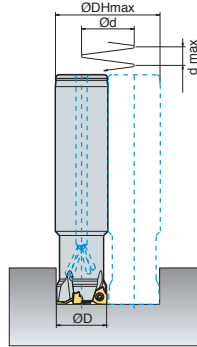

3. Helical cutting for through holes

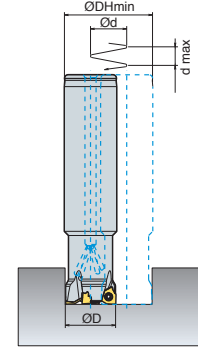

(mm)

| Designation | Tool Dia. ØD | Depth of cut ap | 1. Ramping | | 2. Helical cutting for blind holes | | | | 3. Helical cutting for through holes | | |
|-------------|--------------------|-----------------|--------------------|------|------------------------------------|-----------------|-----------------------------|-----------------|--------------------------------------|-----------------|-----|
| | | | Max. rake angle α° | Lmin | Min. machining Dia. Ø DHmin | Max. pitch dmax | Max. machining Dia. Ø DHmax | Max. pitch dmax | Min. machining Dia. Ø DHmin | Max. pitch dmax | |
| RM6PS | 032R-2W32-120-WN08 | 32 | 8 | 4.6 | 99.5 | 54 | 4.5 | 62 | 5.2 | 38.5 | 3.2 |
| | 040R-3W32-120-WN08 | 40 | 8 | 4.2 | 109 | 69 | 5.3 | 78 | 6.0 | 54.5 | 4.2 |
| | 050R-4W32-120-WN08 | 50 | 8 | 4.0 | 114.5 | 89 | 6.5 | 98 | 7.2 | 74.5 | 5.5 |
| RM6PCM | 063R-22-6-WN08 | 63 | 8 | 4.0 | 114.5 | 115 | 8.0 | 124 | 8.0 | 100.5 | 7.4 |
| | 080R-27-7-WN08 | 80 | 8 | 3.5 | 131 | 149 | 8.0 | 158 | 8.0 | 134.5 | 8.0 |
| | 100R-32-8-WN08 | 100 | 8 | 2.6 | 176.5 | 189 | 8.0 | 198 | 8.0 | 174.5 | 8.0 |
| | 125R-40-11-WN08 | 125 | 8 | 1.8 | 255 | 239 | 8.0 | 248 | 8.0 | 224.5 | 7.8 |

* $L_{min} = ap / \tan(\alpha^\circ)$

Lmin : Cutting length at min. rake angle
ap : Axial depth of cut
α° : Available rake angle for ramping

Available Inserts

(mm)

| Shape | Designation | Coated | | | | | Dimensions (mm) | | | | Figure | |
|-------|-------------|---------------|--------|--------|--------|--------------|-----------------|------|-----|---------|--------|-----|
| | | PC3600 | PC5300 | PC5400 | PC6510 | Uncoated H01 | d | t | r | Max. ap | | |
| | WNGX | 040304PNFR-MA | | | | | 7.0 | 3.46 | 0.4 | 4.3 | | |
| | | 040308PNFR-MA | | | | | 7.0 | 3.46 | 0.8 | 4.3 | | |
| | | 040312PNFR-MA | | | | | 7.0 | 3.46 | 1.2 | 4.3 | | |
| | | 040316PNFR-MA | | | | | 7.0 | 3.46 | 1.6 | 4.3 | | |
| | | 080604PNFR-MA | | | | | 13.0 | 6.4 | 0.4 | 8.2 | | |
| | | 080608PNFR-MA | | | | | ● | 13.0 | 6.4 | 0.8 | | 8.2 |
| | | 080612PNFR-MA | | | | | | 13.0 | 6.4 | 1.2 | | 8.2 |
| | | 080616PNFR-MA | | | | | | 13.0 | 6.4 | 1.6 | | 8.2 |
| | | 080620PNFR-MA | | | | | | 13.0 | 6.4 | 2.0 | | 8.2 |
| | WNGX | 040304PNER-ML | | | | | 7.0 | 3.46 | 0.4 | 4.3 | | |
| | | 040308PNER-ML | | | | | 7.0 | 3.46 | 0.8 | 4.3 | | |
| | | 040312PNER-ML | | | | | 7.0 | 3.46 | 1.2 | 4.3 | | |
| | | 040316PNER-ML | | | | | 7.0 | 3.46 | 1.6 | 4.3 | | |
| | | 080604PNER-ML | ● | ● | ● | | 13.0 | 6.4 | 0.4 | 8.2 | | |
| | | 080608PNER-ML | ● | ● | ● | | 13.0 | 6.4 | 0.8 | 8.2 | | |
| | | 080612PNER-ML | | | | | 13.0 | 6.4 | 1.2 | 8.2 | | |
| | | 080616PNER-ML | | | | | 13.0 | 6.4 | 1.6 | 8.2 | | |
| | | 080620PNER-ML | | | | | 13.0 | 6.4 | 2.0 | 8.2 | | |
| | WNGX | 040304PNSR-MM | | | | | 7.0 | 3.46 | 0.4 | 4.3 | | |
| | | 040308PNSR-MM | | | | | 7.0 | 3.46 | 0.8 | 4.3 | | |
| | | 040312PNSR-MM | | | | | 7.0 | 3.46 | 1.2 | 4.3 | | |
| | | 040316PNSR-MM | | | | | 7.0 | 3.46 | 1.6 | 4.3 | | |
| | | 080604PNSR-MM | ● | ● | | | 13.0 | 6.4 | 0.4 | 8.2 | | |
| | | 080608PNSR-MM | ● | ● | | | 13.0 | 6.4 | 0.8 | 8.2 | | |
| | | 080612PNSR-MM | | | | | 13.0 | 6.4 | 1.2 | 8.2 | | |
| | | 080616PNSR-MM | | | | | 13.0 | 6.4 | 1.6 | 8.2 | | |
| | | 080620PNSR-MM | | | | | 13.0 | 6.4 | 2.0 | 8.2 | | |

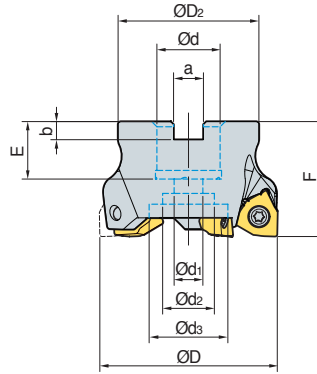
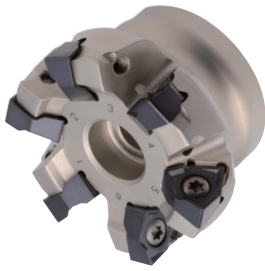
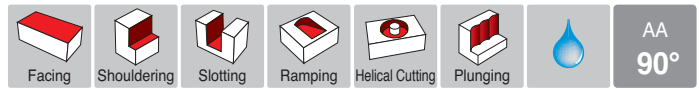

(mm)

| Designation | | ØD | ØD ₂ | Ød | Ød ₁ | Ød ₂ | Ød ₃ | a | b | E | F | ap | | Available screw | |
|-----------------|--------------------|-----|-----------------|----|-----------------|-----------------|-----------------|------|------|-----|----|-----|------|-----------------|-----------|
| RM6PCM | 040R-16-6-WN04 | 6 | 40 | 35 | 16 | 9 | 14 | - | 8.4 | 5.6 | 19 | 40 | 4.3 | 0.19 | ETNA02506 |
| | 040R-16-7-WN04 | 7 | 40 | 35 | 16 | 9 | 14 | - | 8.4 | 5.6 | 19 | 40 | 4.3 | 0.19 | ETNA02506 |
| | 050R-22-8-WN04 | 8 | 50 | 42 | 22 | 11 | 18 | - | 10.4 | 6.3 | 20 | 40 | 4.3 | 0.28 | ETNA02506 |
| | 050R-22-9-WN04 | 9 | 50 | 42 | 22 | 11 | 18 | - | 10.4 | 6.3 | 20 | 40 | 4.3 | 0.28 | ETNA02506 |
| | 063R-22-10-WN04 | 10 | 63 | 49 | 22 | 11 | 18 | - | 10.4 | 6.3 | 20 | 40 | 4.3 | 0.47 | ETNA02506 |
| | 063R-22-11-WN04 | 11 | 63 | 49 | 22 | 11 | 18 | - | 10.4 | 6.3 | 20 | 40 | 4.3 | 0.47 | ETNA02506 |
| | 050R-22-4-WN08 | 4 | 50 | 42 | 22 | 11 | 18 | - | 10.4 | 6.3 | 20 | 40 | 8.2 | 0.28 | FTNA0513 |
| | 050R-22-5-WN08 | 5 | 50 | 42 | 22 | 11 | 18 | - | 10.4 | 6.3 | 20 | 40 | 8.2 | 0.27 | FTNA0511 |
| | 063R-22-5-WN08 | 5 | 63 | 49 | 22 | 11 | 18 | - | 10.4 | 6.3 | 20 | 40 | 8.2 | 0.45 | FTNA0513 |
| | 063R-22-6-WN08 | 6 | 63 | 49 | 22 | 11 | 18 | - | 10.4 | 6.3 | 20 | 40 | 8.2 | 0.45 | FTNA0513 |
| | 080R-27-7-WN08 | 7 | 80 | 57 | 27 | 14 | 20 | 35 | 12.4 | 7 | 23 | 50 | 8.2 | 0.90 | FTNA0513 |
| | 080R-27-9-WN08 | 9 | 80 | 57 | 27 | 14 | 20 | 35 | 12.4 | 7 | 23 | 50 | 8.2 | 0.89 | FTNA0511 |
| | 100R-32-8-WN08 | 8 | 100 | 67 | 32 | 18 | 26 | 42 | 14.4 | 8 | 25 | 50 | 8.2 | 1.47 | FTNA0513 |
| | 100R-32-11-WN08 | 11 | 100 | 67 | 32 | 18 | 26 | 42 | 14.4 | 8 | 25 | 50 | 8.2 | 1.45 | FTNA0511 |
| | 125R-40-11-WN08 | 11 | 125 | 90 | 40 | 22 | 32 | 52 | 16.4 | 9 | 29 | 63 | 8.2 | 2.94 | FTNA0513 |
| 125R-40-14-WN08 | 14 | 125 | 90 | 40 | 22 | 32 | 52 | 16.4 | 9 | 29 | 63 | 8.2 | 2.91 | FTNA0511 | |
| RM6PC | 080R-25.4-7-WN08 | 7 | 80 | 57 | 25.4 | 14 | 20 | 35 | 9.5 | 6 | 25 | 50 | 8.2 | 0.91 | FTNA0513 |
| | 080R-25.4-9-WN08 | 9 | 80 | 57 | 25.4 | 14 | 20 | 35 | 9.5 | 6 | 25 | 50 | 8.2 | 0.91 | FTNA0511 |
| | 100R-31.75-8-WN08 | 8 | 100 | 67 | 31.75 | 18 | 26 | 42 | 12.7 | 8 | 32 | 63 | 8.2 | 1.69 | FTNA0513 |
| | 100R-31.75-11-WN08 | 11 | 100 | 67 | 31.75 | 18 | 26 | 42 | 12.7 | 8 | 32 | 63 | 8.2 | 1.73 | FTNA0511 |
| | 125R-38.1-11-WN08 | 11 | 125 | 90 | 38.1 | 22 | 32 | 52 | 15.9 | 10 | 35 | 63 | 8.2 | 1.98 | FTNA0513 |
| | 125R-38.1-14-WN08 | 14 | 125 | 90 | 38.1 | 22 | 32 | 52 | 15.9 | 10 | 35 | 63 | 8.2 | 2.90 | FTNA0511 |

Available Arbors

| Cutter designation | NC arbors |
|------------------------------|---------------|
| RM6PCM 040R-16-6-WN04 | BT□□-FMC16-□□ |
| 040R-16-7-WN04 | |
| 050R-22-8-WN04 | BT□□-FMC22-□□ |
| 050R-22-9-WN04 | |
| 063R-22-10-WN04 | |
| 063R-22-11-WN04 | |
| 050R-22-4-WN08 | |
| 050R-22-5-WN08 | |
| 063R-22-5-WN08 | |
| 063R-22-6-WN08 | |

| Cutter designation | NC arbors |
|-------------------------------|------------------|
| RM6PCM 080R-27-7-WN08 | BT□□-FMC27-□□ |
| 080R-27-9-WN08 | |
| 100R-32-8-WN08 | BT□□-FMC32-□□ |
| 100R-32-11-WN08 | |
| 125R-40-11-WN08 | |
| 125R-40-14-WN08 | BT□□-FMC40-□□ |
| RM6PC 080R-25.4-7-WN08 | BT□□-FMA25.4-□□ |
| 080R-25.4-9-WN08 | |
| 100R-31.75-8-WN08 | BT□□-FMA31.75-□□ |
| 100R-31.75-11-WN08 | |
| 125R-38.1-11-WN08 | BT□□-FMA38.1-□□ |
| 125R-38.1-14-WN08 | |

Parts

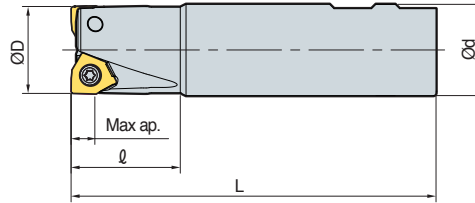

| Specification | Screw | Wrench | Wrench |
|---------------|-------------------|--------|----------|
| WNGX04 | ETNA02506 | TW07S | - |
| WNGX08 | FTNA0511/FTNA0513 | - | TW20-100 |



(mm)

| Designation |  | ØD | Ød | l | L | ap |  | Available screw |
|--------------|---|----|----|----|----|-----|---|-----------------|
| RM6PS | 020R-2W20-110-WN04 | 2 | 20 | 20 | 35 | 110 | 0.22 | ETNA02506 |
| | 020R-3W20-110-WN04 | 3 | 20 | 20 | 35 | 110 | 0.22 | ETNA02506 |
| | 025R-3W25-110-WN04 | 3 | 25 | 25 | 35 | 110 | 0.36 | ETNA02506 |
| | 025R-4W25-110-WN04 | 4 | 25 | 25 | 35 | 110 | 0.35 | ETNA02506 |
| | 032R-5W32-110-WN04 | 5 | 32 | 32 | 35 | 110 | 0.60 | ETNA02506 |
| | 032R-6W32-110-WN04 | 6 | 32 | 32 | 35 | 110 | 0.60 | ETNA02506 |
| | 032R-2W32-120-WN08 | 2 | 32 | 32 | 40 | 120 | 0.65 | FTNA0513 |
| | 040R-3W32-120-WN08 | 3 | 40 | 32 | 40 | 120 | 0.69 | FTNA0513 |
| | 040R-4W32-120-WN08 | 4 | 40 | 32 | 40 | 120 | 0.69 | FTNA0513 |
| | 050R-4W32-120-WN08 | 4 | 50 | 32 | 40 | 120 | 0.76 | FTNA0513 |
| | 050R-5W32-120-WN08 | 5 | 50 | 32 | 40 | 120 | 0.76 | FTNA0513 |

Parts

| Specification | Screw  | Wrench  | Wrench  |
|---------------|--|---|---|
| WNGX04 | ETNA02506 | TW07S | - |
| WNGX08 | FTNA0513 | - | TW20-100 |



Holystar B/D, 1350, Nambusunhwan-ro, Geumcheon-gu, Seoul, 08536, Korea
 Tel : +82-2-522-3181 Fax : +82-2-522-3184, +82-2-3474-4744 Web : www.korloy.com E-mail : export@korloy.com

KORLOY AMERICA

620 Maple Avenue, Torrance, CA 90503, USA
 Tel : +1-310-782-3800 Toll Free : +1-888-711-0001 Fax : +1-310-782-3885
 www.korloyamerica.com E-mail : sales@korloy.us

KORLOY INDIA

Plot NO.415, Sector 8, IMT Manesar, Gurgaon 122051, Haryana, INDIA
 Tel : +91-124-4391790 Fax : +91-124-4050032
 www.korloyindia.com E-mail : sales.kip@korloy.com

KORLOY EUROPE

Gablonzer Str. 25-27, 61440 Oberursel, Germany
 Tel : +49-6171-277-83-0 Fax : +49-6171-277-83-59
 www.korloyeurope.com E-mail : sales@korloyeurope.com

KORLOY BRASIL

Av. Aruana 280, conj.12, WLC, Alphaville, Barueri,
 CEP06460-010, SP, Brasil
 Tel : +55-11-4193-3810 E-mail : vendas@korloy.com